

## TRANSIENT OVERVOLTAGE PROTECTION FOR ELECTRONIC MEASUREMENT DEVICES

Bob Garner

ZeroDT LLC

### Introduction

Measurement, control, and automation are critical to today's business environment. However, the electronics that enable these systems to function, and make these systems so valuable, can be vulnerable to the damaging effects of overvoltage transients. The damage can easily be seen when components or equipment has been transformed to charred ruins and slag metal, but many times the damage is not readily visible and/or may show up in the future as glitches or inconsistencies. This paper will explore the sources of these transient overvoltages, how they get into the systems, and an approach to protection of these critical systems that can, along with the technologies (and their tradeoffs) that we can employ, to greatly enhance the survivability of the electronic equipment.

### Common Misconceptions

Also referred to as excuses on why folks think they don't need to worry about protecting against transient overvoltages.

- "We ground everything, so we don't have to worry about surges"
- "We don't ground anything, so we don't have to worry about surges"
- "These communication circuits and are not connected to the grid, so we don't have to worry about surges"
- "I have a fuse / breaker in the circuit already, so it is protected"
- "We use a UPS (Uninterruptible Power Supply), so we don't have surges"
- "These are small gauge conductors and can't carry enough current to do damage"
- "Our equipment doesn't get struck by lightning"
- "We have a lightning protection system"

As we go thru this discussion of transient protection, we will learn why these are misconceptions and what a better approach may be.

### What is a transient overvoltage?

tran·sient /'tranzHənt, 'tranzēənt/ adj. -- lasting only for a short time; impermanent

When discussing transient overvoltages on AC systems we are referring to an excess voltage that has a duration of a small fraction of a complete AC power cycle (1/60<sup>th</sup> of a second, or 16.67 ms).

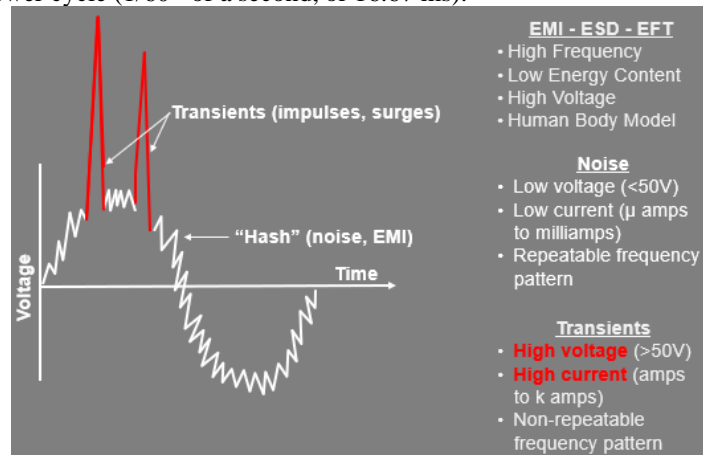

Typical durations are <2 ms for switching transients and are <40 μs for lightning transients. Because of the high voltage and high currents associated with transients and they are the causes of equipment damage, we will focus on them.

### Where do these transient overvoltages come from?

Probably the most visible source of transient overvoltages, and the one that jumps to the front of everyone's mind, is lightning.

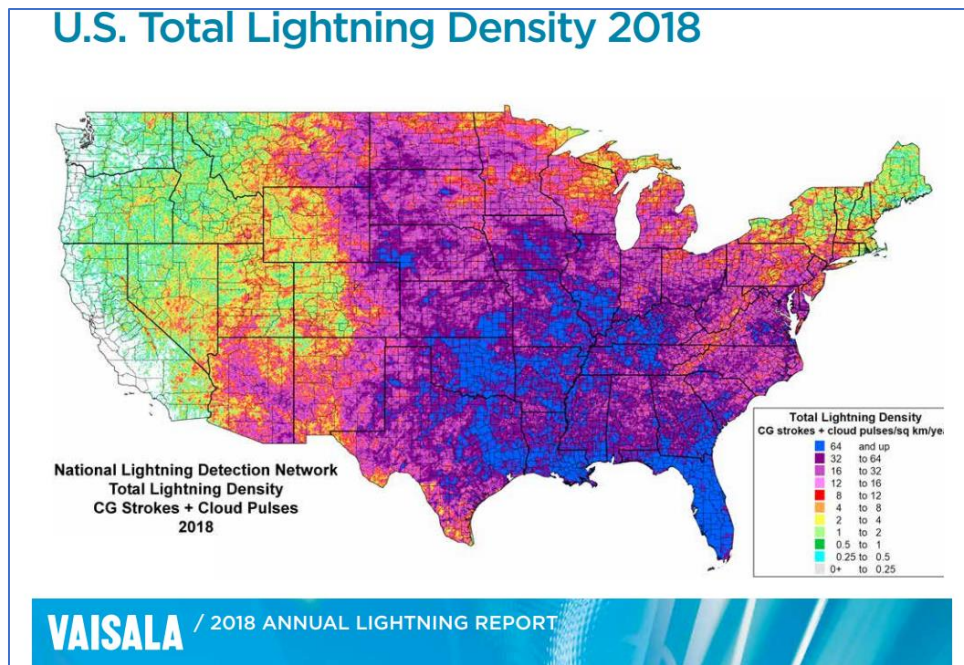

However, lightning is not the only source of overvoltage transients. Anytime we have a current switched on/off, we have transient voltage generated. Remember a flowing current will generate a magnetic field and when that current is interrupted, or switched off, the magnetic field collapses and generates a transient voltage in the conductor. This means switching any large load currents such as seen with utility grid switching, pumps, motors, valves, compressors, HVAC .... can generate transient overvoltages that will back feed into the power system and find its way to any equipment connected to it. Even in your home or office, switching of loads such as HVAC, compressors, chillers, other motors, will generate transients. These switching transients have lower magnitudes than we see with lightning effects, but they are much longer in duration (up to 2 ms vs 40  $\mu$ s with lightning induced transients). We will talk more about transient durations when we discuss suppression technologies later in the paper.

#### How do these transients get into our systems?

**Direct** -- The most obvious way for these transient overvoltages to get into our systems is 'direct coupled' or conducted into the system via a common impedance or direct cables. Direct strikes into the AC power system do occur but are relatively infrequent due to the safeguards built into the AC power grid. When these direct strikes occur, high voltage arrestors and network component designs help to mitigate the effect of amount of energy entering the system, but there still is a high probability of equipment damage.

**Indirect** -- Transients can also indirectly enter our systems thru either inductively or capacitance coupling. Let's look at inductively coupling first. When a lightning strike occurs, there are very high electrical currents taking place (they can be hundreds of kilo-Amperes, kA, of current). These large currents switching on and then off generate a large electromagnetic wave (radio wave) that propagates in all directions from the lightning strike/discharge. When that electromagnetic wave crosses a conductor, a voltage is generated at that point on that conductor that is proportional to the magnitude of the electromagnetic wave (just like a radio signal generates a voltage on an antenna). This transient voltage on the conductor is trying to find its way to Ground/Earth and will travel both directions along that conductor. Because the magnitude of the currents in lightning strikes is so large, we can have very large transient voltages generated in conductors from strikes that occurred a mile or more away. Studies have also shown that the number of induced transients can be two orders of magnitude more than the number of direct strikes even for a large tower with air terminal (lightning rods).

**TRUTH -- Damage comes from the NEARBY (Indirect) strikes as well as the direct strikes**

Likewise, if we have conductors running along side of each other and one of the conductors has a transient voltage on it, there can be capacitive coupling that will cause a transient voltage to appear on the other conductors. The capacitive coupling is based on the voltage field around a conductor, while the inductive coupling is caused by the magnetic field.

The important issues to remember are that we can have transients in our systems without any direct connection to the transient source and installation practices can have significant impacts on the propagation of transient overvoltages in our systems.

What sort of voltages and/or currents are we talking about?

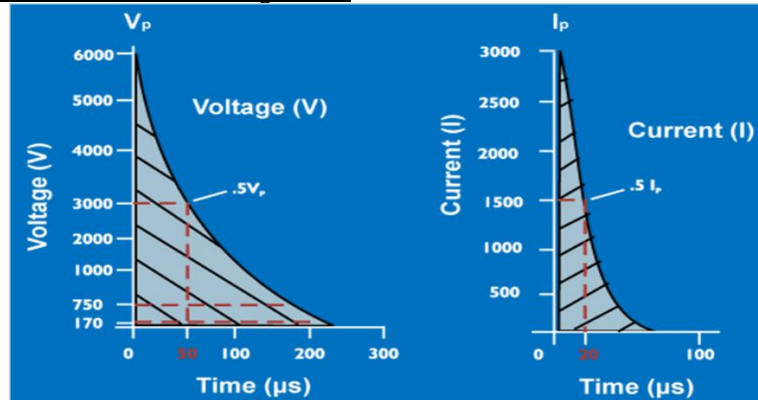

ANSI Standard c62

The above illustrates the 1.2/50 μs (voltage) and 8/20 μs (current) waveform models used for nearby strikes. These models have been around for many years and are also the waveforms used for testing in UL 1449 Standard for Surge Protective Devices. The important characteristics to note are the fast rise times 1.2 μs for the voltage and 8 μs for the current and that the duration is relatively short as well. The 50% decay times are 50 μs for the voltage and 20 μs for the surge current. The values are what can be expected to be seen at the service entrance for AC power in the United States.

Smaller gauge conductors with their higher impedances would be expected to exhibit lower magnitudes of voltage and current, but the waveform shape is still valid. For example, small diameter wires used for data communications may routinely have surge currents of up to 500 to 600 amps induced on them (again the duration is only tens of microseconds).

**TRUTH -- Damage can come on ANY conductor, not just the AC power connections.**

Ohm's Law continues to be TRUE !

How many times do we go back to Ohm's Law  $V = I \times R$

This can also be stated such that current will flow from the point of highest potential to a point of lower potential, or if points are at the same voltage (equipotential) then there will no current flow. By proper grounding and bonding we can strive to have the potential of all equipment rise and fall together and doing this will minimize the currents that cause damage. When we are looking at Grounding and Bonding from a protection against transient overvoltage point of view, we must consider the response to high frequencies. Because of the very fast rise and fall times (and short duration) of the transient overvoltages, the most significant factor in the impedance between points is the inductance (the impedance will go up directly with the inductance). The reactance of an inductor is  $Z_L = \omega L$ , so if the frequency ( $\omega$ ) is a very large number, then the reactance/impedance is a very large value even if L is small.

How can we protect the equipment from these transient overvoltages?

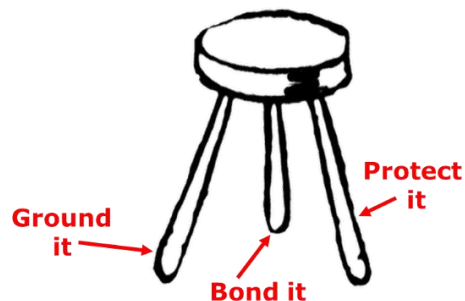

By taking 3 relatively simple steps we can help ensure the survivability of our equipment:

1. Provide a Ground/Earth system to efficiently disperse any overvoltage transient energy into the Ground/Earth.
2. Bond the equipment such that the equipment rises and falls in potential/voltage together (equipotential).
3. Provide surge protection on all external conductors to provide a low-impedance path for overvoltage transient energy to get to Ground/Earth without going thru our equipment.

Like the simple 3-legged milking stool, if we provide all 3 legs we have a stable solution, but if we fail to provide any one leg, the stool fails or falls over.

Grounding

A Grounding or Earthing system is an essential electrical support system that efficiently releases energy into the earth safely. This system will consist of one or more ground electrodes, and low impedance (not just low resistance) ground conductors intentionally connected together with sufficient current carrying capacity to prevent the buildup of voltages and conduct fault currents.

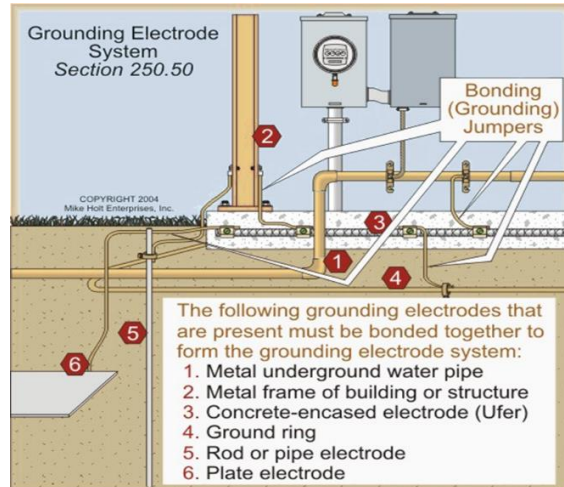

Samples of Ground Electrodes, Mike Holt Enterprises, Inc.

The design, implementation, and regulations concerning ground electrode systems and regulation of ground systems is a subject in itself that goes well beyond the scope and breadth of this paper so we will limit the discussion to note that efficient grounding systems are vital equipment protection as well as equipment operation and life safety.

Bonding

Definition -- The permanent joining of metallic parts to form an electrically conductive path that ensures electrical continuity and the capacity to conduct safely any current likely to be imposed. However, for equipment to be protected bonding needs to be more than just the protection against electrical shock, we need to intentionally bond our equipment such that all of the equipment is at the same voltage potential (even under transient conditions). Currents will flow from points of higher voltage to lower voltage, so equipotential bonding can prevent large damaging currents from one device to another. As stated previously, the goal is for all of the equipment to rise and fall together in potential/voltage.

Surge Protection

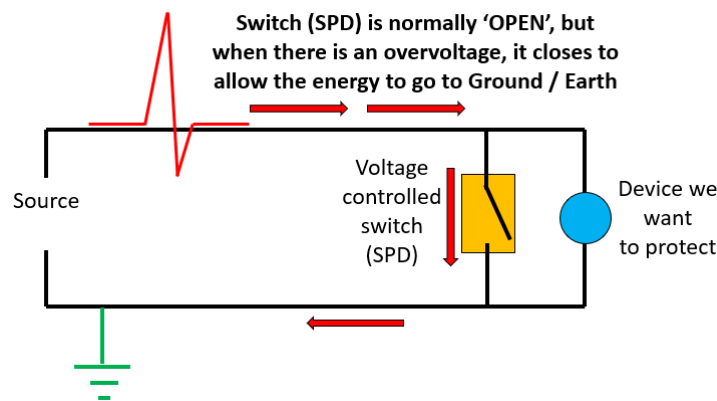

We want to limit the amount of overvoltage transient energy that our device sees by diverting it to Ground/Earth thru our ground electrode system. Ideally this surge protector should be essentially invisible to our equipment, in regard to both the communications as well as the actual measurements they are performing. One way to think of the surge protector is that it acts like a pressure relief valve – when the pressure (voltage) being applied to our device gets to high, the relief valve (our surge protector) opens and diverts the energy to an alternate path to Ground/Earth instead of thru our device. We want this alternate path to have as low of impedance as possible so that most of the surge energy will take this parallel path.

### Surge Protection Technologies (How do we get the energy to Ground/Earth)

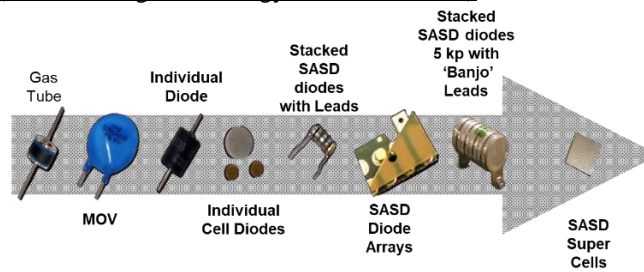

In order for the Surge Protective Device (SPD) to limit the transient overvoltage or divert the surge current we need a device that has a non-linear characteristic such as a Gas Discharge Tube (GDT), Metal Oxide Varistor (MOV) or Silicon Avalanche Suppression Diode (SASD). There are other devices that can be used as well but most commercially available SPD use one or more of these technologies.

#### Gas Discharge Tubes (GDTs)

One of the oldest technologies used for surge protection is the Gas Discharge Tube (GDT). The GDT is made up of two metal electrodes sealed in an enclosure that is filled with an ionizing gas. This is done to control the voltage at which an arc is struck between the electrodes. Once the arc is ignited, the impedance of the device drops to a low value (it 'crowbars') until all of the energy is shunted and the voltage drops below it's 'extinguish voltage' (minimum voltage necessary to maintain the arc). One thing to note is that if there is a DC voltage on the line, the GDT may go into a 'glo-mode' shunting the DC current until some other means interrupts the circuit.

GDTs can be designed to handle very large surge currents, but they also have a limited usage life. The arc destroys part of the metal electrodes each time the device operates (the amount of damage is related to the magnitude of the arc current). The damage or degradation to the electrodes will impact the voltage at which the arc will ignite, and therefore the turn-on value for the device will change with usage. It should also be noted that numerous small surge events can have the same electro damage as a single large event. The other issue with using GDTs as surge protective devices is that the 'response time' (time for the arc to ignite) can vary depending on the surge waveform.

#### Metal Oxide Varistors (MOVs)

A varistor is an electrical device that changes resistance depending on the applied voltage.

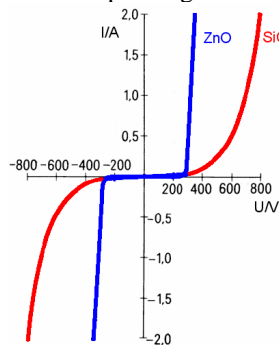

In the early 1970's GE commercialized varistors that were made from metal oxides (ZnO). These Metal Oxide Varistors (MOVs) were a step forward in surge suppression as they had a consistent fast response time and did not exhibit the crow-bar characteristics of GDTs. However, like GDTs, the MOV also suffers degradation of its performance based on usage. The amount of degradation/damage to the device is related to both the magnitude of the current conducted during the event, as well as the duration of event. The degradation of the device shows up as changes to its turn-on voltage characteristics as well as the impedance of the device while it is conducting current.

#### Silicon Avalanche Suppression Diodes (SASDs)



Avalanche diodes are very similar to Zener diodes but break down by a different mechanism: the avalanche effect. Avalanche diodes are designed to break down at a well-defined reverse voltage without being destroyed or damaged. This occurs when the reverse electric field applied across the p-n junction causes a wave of ionization reminiscent of an avalanche,

leading to a large current. In addition, the p-n junction of SASDs have much larger cross-sectional area than those of a normal diode, allowing them to conduct large currents to Ground/Earth without sustaining damage. The actual response time (clamping time) of SASD is roughly one picosecond, but in a practical circuit the inductance of the wires leading to the device impose a higher limit.

When TVS diodes and SASDs were introduced into market in the late 60's, the surge current capability of the individual diodes was limited and their use in practical protectors required large numbers of individual cells and innovative designs. As semiconductor technology has advanced today's individual SASDs are capable of very large surge currents and are an economical solution. Their real advantage over the other technologies is their ability for continued usage without degradation. Don't take this the wrong way, these devices will fail if subjected to surge currents that are larger than their junctions can conduct, but if the devices are chosen correctly for the intended application, they will conduct the surge currents and return/reset to normal operation without damage or degradation.

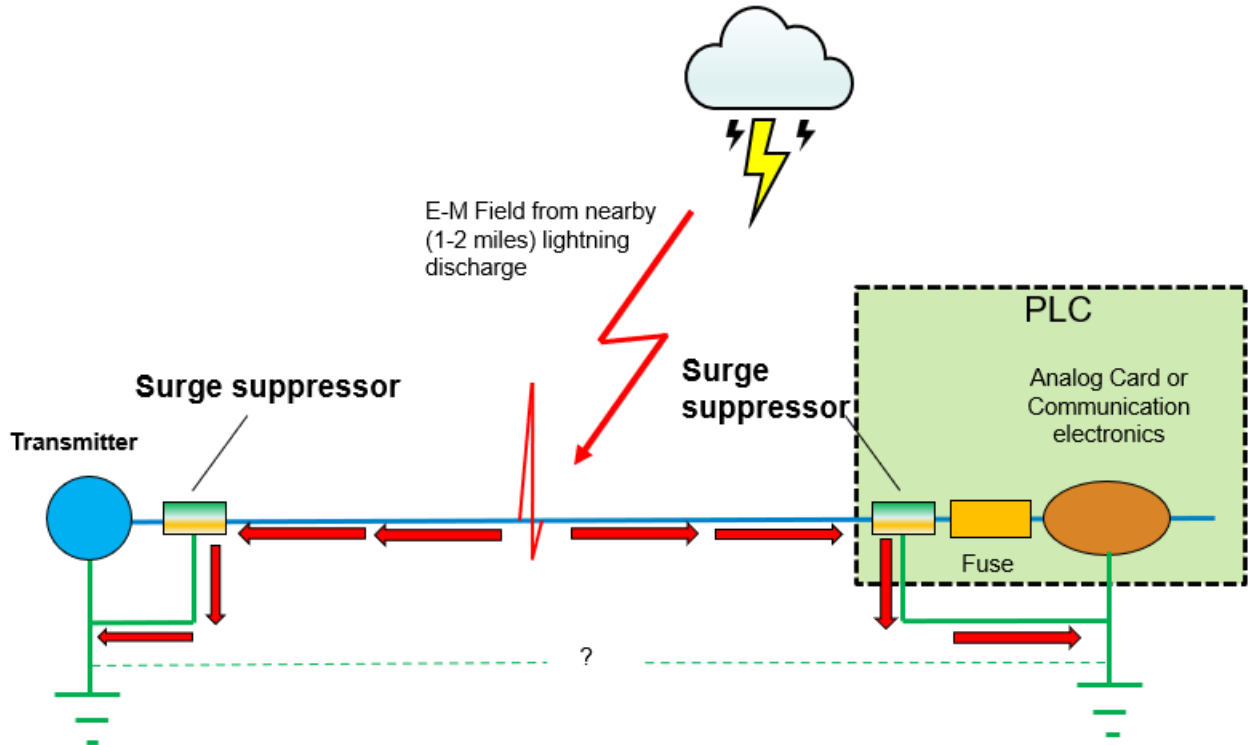

Special Challenge – RF lines (coax)

In our discussions up to this point, we have used examples and illustrations where the transient overvoltage is higher in frequency than the AC or DC power or communications signals that we are trying to allow to pass. The inductance of the conductors/cables make the line have a high impedance to the higher frequency components of the transient. However, we also run into many situations where the cable is specifically designed to pass higher frequencies – for example the coax cable between the antenna and the transmitter/receiver. Because this cable is low in inductance in order pass the radio signals with low loss, it also passes the frequency components of the transients with little to no loss as well. This requires that we pay special attention to any rf paths that could conduct transient overvoltage. The simplest protection scheme is to place a SPD between the core and the shield of the coax to 'clamp' the overvoltage. Many manufacturers of RF coaxial protectors utilize a GDT for this application because of their relatively small size and ability to conduct very large surge currents.

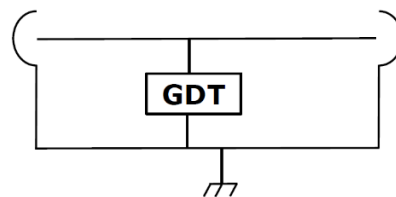

Simplified schematic of a gas tube coaxial protector

We have already discussed some of the issues of using GDTs including their turn-on response and degradation with usage. Because of this, manufactures have added “DC blocks” to significantly reduce the energy let thru to the equipment that is being protected.

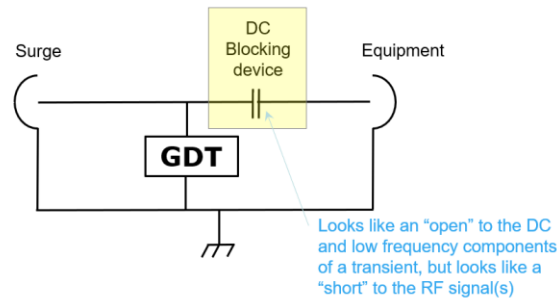

Simplified schematic of a DC blocked gas tube coaxial protector

This greatly improves the protection by filtering off much of the lower frequency components of the transient overvoltage, but still relies on the GDT for its primary suppression. What if we were to replace the GDT altogether with a device that looks like a short to the DC and low frequency components, but still looked like a high impedance (or an open) to the RF signals?

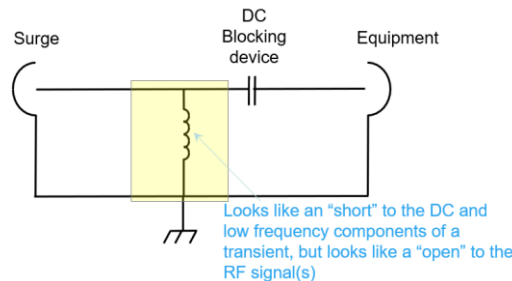

This not only eliminates the issues with the GDT, but it further reduces the energy let thru to the equipment. This design can be enhanced even further by adding another inductor to the Equipment side of the DC Blocking device and making the unit bidirectional. The only problem is that the unit will not pass any DC power on the coax for tower top electronics such as a block down converter or amplifier. Because of these needs for DC power, manufacturers have implemented designs like the example below to pass the DC but still provide the necessary equipment protection.

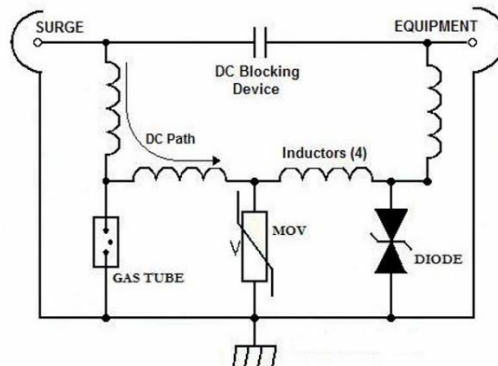

Rules of Thumb helpful in applying equipment protection

- Always mount the suppressor as close as possible to the equipment being protected.
- Lead length must be as short and as direct (no sharp bends) to avoid an increase in the protection level seen by the equipment.
  - The self-inductance of the leads (especially if they have any loops or bends) will add significantly to the voltage level of the protector so that the device being protected will experience a much higher voltage.*
- Every conductive path (wire/cable) is a possible transient path to your equipment.
  - Every conductor (AC power, DC power, data comms, analog sensors, CAT 5/6 cables, . . .) can have an induced transient on it that is trying to find its way to Ground/Earth.*

### Common Misconceptions -- revisited

Also referred to as excuses on why folks think they don't need to worry about protecting against transient overvoltages.

- “We ground everything, so we don't have to worry about surges”
  - Grounding alone isn't enough to protect equipment from surges,
- “We don't ground anything, so we don't have to worry about surges”
  - There are usually ground paths unless extreme care is taken to eliminate them (isolation) and path to Ground/Earth, even one with a high impedance, can cause damage to your equipment.
- “These communication circuits and are not connected to the grid, so we don't have to worry about surges”
  - Cables can be isolated from the grid and still have surges induced on to them.
- “I have a fuse / breaker in the circuit already, so it is protected”
  - Fuses/breakers are over-current devices, not overvoltage devices and their response times are way too slow to protect against transient damages.
- “We use a UPS (Uninterruptible Power Supply), so we don't have surges”
  - UPSs are designed to prevent power dropouts of a cycle or more, they are not intended to prevent transient overvoltages.
- “These are small gauge conductors and can't carry enough current to do damage”
  - Even the conductors in a CAT 5/6 cable can carry enough surge energy to damage equipment
- “Our equipment doesn't get struck by lightning”
  - That may be the case, but if there are lightning discharges within a mile or 1.5 miles, your equipment can still be subjected to indirect transient over-voltages.
- “We have a lightning protection system”
  - A lightning protection system (LPS) is designed to protect structures and/or equipment by controlling the energy of lightning discharges. Your equipment will still be susceptible to effects of induced surge currents.

### Conclusions

As we have previously described, by taking 3 relatively simple steps we can help ensure the survivability of our equipment:

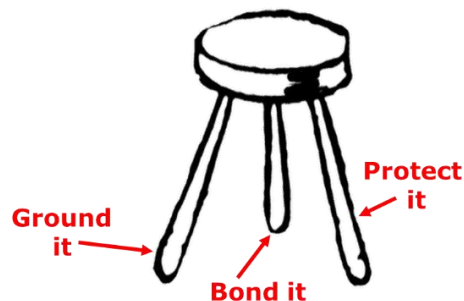

1. Provide a Ground/Earth system to efficiently disperse any overvoltage transient energy into the Ground/Earth.
2. Bond the equipment such that the equipment rises and falls in potential/voltage together (equipotential).
3. Provide surge protection on all external conductors to provide a low-impedance path for overvoltage transient energy to get to Ground/Earth without going thru our equipment.

**If we provide all 3 components, we will greatly enhance the survivability of the equipment.** Experience has shown that these steps, can eliminate damage where previously damage occurred on a routine basis.