

# DEW POINT WET GAS AND ITS EFFECT ON NATURAL GAS SAMPLING SYSTEMS

Philip A Lawrence

ENABLE™ Midstream Partners

## INTRODUCTION

Wet gas measurement is becoming widely used in the modern oil and gas market place. The effect of entrained liquid in gas and its impact on measurement systems is being researched world-wide by various laboratories and JIP working groups. The impact can be very significant financially. Hydrocarbon Dew Point can also effect the financial operation of a gas transportation company if not managed effectively amounting to hundreds of thousands of dollars per annum based on incorrect sampling and its subsequent analysis.

The subject is quite large and encompasses many different concepts, meter types, standards and opinions, with many new ideas brought to the forefront each year as more research is done. From upstream applications to midstream measurement issues caused by liquid drop out in the pipelines where gas gathering systems are used.

The issue of liquid entrained gas is becoming a big issue! Small quantities of hydrocarbon liquid in a gas sample stream can have a large impact on the BTU value analysis and cause large losses or gains depending on which side of the financial fence you are.

This paper will describe the phenomenon of wet gas, liquid drop out and some of the various types of measurement concepts that are and may be used for these types of measurement, together with some recent thinking and concepts associated with wet gas measurement.

The paper will mention some of the terms and mathematical concepts used to enable the reader to grasp a better understanding of what this stuff is about together with some information on wet gas impact in the high gas volume fraction (GVF) applications and sample collection.

The paper is divided into sections and will discuss the various levels of wet gas, dew point and liquid ratios in natural gas. Some of the measurement objectives derived from a wet gas methods are:

- Reservoir and well management,
- Production optimisation,
- Production (gas, condensate and water) allocation
- Formation water breakthrough detection,
- Flow assurance, e.g. hydrates, scale, salt deposition
- Effective Sampling and the Financial effect on Mid-Stream transportation systems.
- Dew Point and its Effect on Hydrocarbon Measurement.

## HYDROCARBON DEW POINT

The determination of hydrocarbon dew point (HCDP), the temperature at a defined pressure at which hydrocarbon liquids begin to form, has become critical for the natural gas industry.

A big reason is that producers are focusing on extracting heavier gases in traditional and shale plays in an effort to produce more profitable natural gas liquids (NGLs) rather than the natural gas that is selling at historical lows.

This has increased the risk of hydrocarbon liquids entering or forming in gas transmission networks if this rich gas is not fully processed correctly the impact is large.

Hydrocarbon liquids in the gas stream may also cause hydrate formation, increase compression costs, cause issues with pressure regulator freezing, and lead to damage of gas turbines and other end-user equipment.

This can occur when the hydrocarbon liquids entering the transmission network are not measured through gas metering stations or the high-energy heavy hydrocarbons drop out as condensate (or “drip”).

In the transmission network, the energy content of the gas leaving the network is less than the energy of the gas entering the network, resulting in increases in lost and unaccounted for (L&U) energy. Therefore, it is understandable that custody transfer agreements are increasingly specifying limits for the hydrocarbon dew point.

The traditional method of determining the hydrocarbon dew point online is to use a chilled-mirror device that reduces the temperature of a mirror in a measurement chamber filled with the natural gas until enough hydrocarbon mist condenses on the mirror so to be detected.

Other dedicated HCDP analyzers using different measurement techniques are also available; however, they all provide a HCDP only at a single pressure and are dedicated analyzers that provide a single measurement.

Other methods using a dedicated HCDP analyzer is by using an equation of state (EOS) to calculate the hydrocarbon dew point at any pressure from the composition obtained from a gas chromatograph (GC).

Normally by entering the composition of the natural gas into a recognized equation of state, the theoretical HCDP is calculated for any pressure as well as the Cricondetherm (the highest dew point temperature at any pressure). See figure 1.0.

The validity of the calculated value depends on the accuracy of the composition used especially for the higher carbon number hydrocarbons (C6 to C9). The two most commonly used and accepted equations of state are:

- 1) **Peng-Robinson (PR)** (1976) equation of state - This is the most commonly used method for “pipeline quality gas.”
- 2) **Redlich-Kwong-Soave (RKS)** (1972) equation of state – Improvements by Soave on the original Redlich-Kwong (1949) equation of state. (As can be seen the inception of this this was pretty old circa 1949.

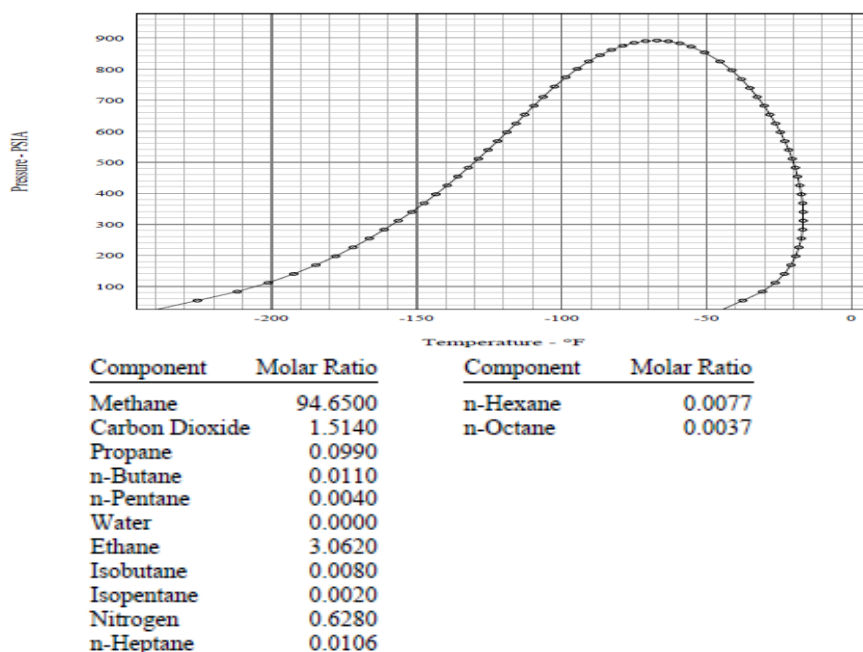

**Figure 1. Typical Curve Calculated from Equation of State Based on Component Values**

## NATURAL GAS CHROMATOGRAPHY

Natural Gas Chromatography is used in custody transfer measurement applications where high volumetric rates are evident to determine the energy content, compressibility, density, and other physical properties. Therefore, using a gas chromatograph to determine the HCDP using an EOS provides additional valuable information from equipment being used already. The ability to calculate the HCDP at any pressure opens up some very practical applications that can significantly improve measurement and lower lost and unaccounted for energy.

Flow measurement devices used in custody transfer (such as orifice meters, turbines and ultrasonic flow meters) are designed to measure single-phase gas flow with uncertainties typically below +/- 0.5%. However, the uncertainty significantly increases when hydrocarbon liquids form.

A gas chromatograph that is capable of calculating the HCDP at any pressure enables a very useful operational diagnostic that is used to try to avoid two-phase flow, and a subsequent incorrect measurement. In normal single-phase gas flow conditions, the HCDP of the gas is less than the flowing temperature and all of the hydrocarbons are in the gas phase. If the gas becomes richer and the HCDP of the mixture increases above the pipeline temperature, the heavy hydrocarbons will drop-out into the liquid phase and the remaining gas will have a HCDP equal to the flowing temperature. By calculating the HCDP at the current pipeline pressure and comparing it to the current pipeline temperature, the operator can determine if there is two-phase flow.

By setting an alarm so that if the HCDP temperature is within a certain range (say 10°F) of the flowing temperature, the operator can also have an early warning that two-phase flow (and thus, inaccurate flow measurement) is about to occur (Figure 1). When this alarm occurs, the producer can make corrective actions in their process to avoid the HCDP increasing further and moving into the two-phase flow region where the accuracy of the flow measurement is degraded.

## **VOLUMETRIC MEASUREMENT EFFECTS**

Zanker and Brown (2002) reported errors up to five percent with stratified flow through ultrasonic meters his was due to effects on the ultrasound transducers and also increased gas velocity(over reading) due to space taken up in the pipe by the liquid.

Some meters have the ability to detect when there is two-phase flow; however, this is too late to take corrective action as the flow metering accuracy is already being compromised by that time.

## **HISTORY**

The concept of entrained liquid effecting a gas meters performance was looked at many years ago an American research engineer Dr. J.W. Murdoch, he produced a document from research showing “the effect of liquid over-reading” the publication showing the data is available as written by Murdock and is entitled, “Two-Phase Flow Measurement with Orifices”, Journal of Basic Engineering, pp.419-433 1962. “Murdock, J.W.

Other wet gas researchers have contributed to the development of the subject and a plethora of data and correlations exist to suit different metering type’s concepts and installations. The major metering devices being used are of a differential pressure type due to the robustness of the design.

The subject is hard to deal with because of the lack of test data available to the market place, this sometimes results in data being kept in house and confidential, and the inability to produce a coherent test condition in the laboratory that will match the in-field location is a big issue.

Recent laboratory data shows that even with a well-managed laboratory facility offering various multi-product fluids, at differing pressures and density ratios , it may be impossible to match an “in field condition” which means that any meter correlation, or correction algorithm formed from the data may be suspect in another field condition.

This is not all doom and gloom it is possible to work with data sets that are not exactly ideal, but caution must be taken and the metering system uncertainty or accuracy may need to be relaxed, to allow a sensible operation in the field.

## **WHAT IS WET GAS?**

The term is used to denote a natural gas flow containing a relatively small amount of free liquid by volume; usually this may be limited up to about 10% and requires a lot of study to determine in the field.

There are presently few techniques or methods available, which can measure this type of fluid regime with a reasonable degree of accuracy at higher liquid fractions.

Wet Gas was be considered to be a subset of two-phase flow however newer thinking is moving to looking at the wet gas as a multiphase flow regime!

The phenomenon of wet gas may occur in several ways, for example:

- a) Over time as dry natural gas wells age, changes in flow conditions including a reduction in line pressure may result in the heavier hydrocarbon gases condensing inflow-lines and transportation pipelines.

- b) Production wells for gas condensate fields usually may have wet gas flow.
- c) The quantity of lift gas injected to increase production from many oil wells brings them to flow conditions that may be defined as a wet gas stream.

Many gas wells worldwide are now approaching the latter stages of their production life making wet gas metering more common and driving meter manufacturers and users to new ideas and methodology. An ISO DIS (dissertation) 14532 Standard (terminology) also sights the following wet gas definition:

Wet Gas is defined as gas with inclusion of desirable or undesirable components like water vapour, free water and / or liquid hydrocarbons in significantly greater amounts than those quoted for pipeline quality natural gas.

Typically, a wet gas may consist of unprocessed, (*well head*) or partially processed natural gasses, and may also contain condensed hydrocarbon, traces of carbonyl sulphide and, process fluid vapour such as methanol and glycol.

Wet gas is now being transported in gas gathering lines due to heavy hydrocarbon (C6+) drop out.

The ISO TC 193 WG # 1 Technical Report TR 26762 also refers to wet gas as follows;

Wet Gas (two or three phase) any mixture of gas and up to about 10% by volume liquid hydrocarbon and/or water. The mass ratio of gas to liquid varies significantly with pressure for constant Gas Volume Fraction.

A convenient parameter to indicate the wetness of the gas is the Lockhart & Martinelli Parameter (*XLM*).

### CLASSIFICATION OF WET GAS

In an effort to classify wet gas applications, the literature (et al Mehdizadeh API ,2002) makes a good classification of wet gas metering concepts and places the gas to liquid ratios into three regions by using a term called the Lockhart & Martinelli number (*XLM*) or parameter as a measure of a composite fluids wetness.

The Lockhart & Martinelli parameter can be viewed as the square root of the ratio of the dynamic head associated with the flowing liquid components in a wet gas stream compared with that of the flowing gas components based if the gas and liquids were flowing separately.

This dimensionless number (*XLM*) can be shown in various ways mathematically thus:

$$X_{LM} \equiv \sqrt{\frac{\rho_l V_{s_l}^2}{\rho_g V_{s_g}^2}} = \sqrt{\frac{\rho_l}{\rho_g}} \sqrt{\frac{A^2 V_{s_l}^2}{A^2 V_{s_g}^2}} = \sqrt{\frac{\rho_l}{\rho_g}} \frac{Q_l}{Q_g} \quad .$$

(Equation 1)

Where  $\rho$  is the density,  $V_s$  is the superficial velocity,  $Q$  is flow rate volumetrically, and  $A$  is the cross sectional area of the pipe and the subscripts  $l$  and  $g$  denote the flowing liquid and gas components respectively.

The components and composition of the gas are very important where the BTU values are used to calculate and settle on gas sales contracts whether by transportation or other midstream companies.

The issue today is that particularly the gas boom happening on land-based systems is having the impact of producing natural gas that drop out liquids during transportation.

Also horizontal drilling techniques and well reclamation enhanced recovery are causing higher BTU gas that have higher hydrocarbon dew points as well as liquid ingress from well heads into the gas companies transportation system.

There are three regions of classification and interest in wet gas measurement based on Lockhart & Martinelli numbers derived from an API report - **Type I = ( $XLM < 0.02$ ).** **Type II =  $XLM < 0.02$  to  $< 0.3$**  **Type III =  $0.3 XLM$  or greater values.**

### Type I Wet Gas Applications - have wetness levels in the range of $<0.02$ XLM

This is a low level of wetness and impacts severely gas transportation and midstream companies since the following scenario happens and can cause losses for the entity in question may be amounting to millions of dollars over extended time periods.

Company **a**) collects samples of the wet gas as per the contract and sells the gas to company **b**) based on the BTU value of the gas either as a transporter or gas processor.

Company **b**) requires that collected condensate be allocated back to themselves

Company **a**) then measures the standardized volume and samples the gas fluid using a composite sampler natural gas chromatography or spot sampling methods to allocate the BTU value for the metered streams.

The sample is based on the natural gas collected generally using an approved or standard method however the issue arises when the sample includes the BTU value for the gas together with hydrocarbon liquid trapped in the bottle.

Many newer horizontal drilled systems are passing the condensate into the pipeline on gas gathering then claiming the condensate back but the BTU value may have been included in the sample this means that company **b**) may get benefit from an incorrect sample measurement.

Couple this with the effect of over reading of the gas value across the orifice plates usually used in the buyer-seller contract caused by liquid ingress and this can be a big issue financially.

The over-report characteristics of differential pressure-based flow meters due to wetness have been well and classified/detailed in peer published literature. If the wetness level of a composite wet gas mixture is either known or can be estimated, the impact of the wetness on the gas flow measurement can be mitigated by correcting for the over-report.

Thus, a common approach for Type I gas measurement is to use a standard differential pressure gas flow meter and correct the gas flow measurement based on some estimate of the wetness or not depending on the wetness.

This is the region that affects most mid-stream companies and also up-stream gas companies contracts at the metering interface, this affects the BTU value assessment as mentioned in the example above as well as increased L & U (loss and unaccounted for) which may cause issues with regard to inter-company contract payments and can impact the supplier transporter relationship.

### Type II Wet Gas Applications - having wetness levels in the range of $<0.02$ XLM $<0.3$ XLM.

In these applications, typically both the gas rate and the liquid rate are of interest. Given the objective of measuring both the gas and the liquid rates, Type II wet gas measurements are inherently more difficult than Type I.

A common approach used for Type II applications is to use multiple differential pressure-based devices that have repeatable, but distinct, wetness over-report characteristics in series. The two independent measurements enable the determination of both gas and liquid flow rates.

As noted in the literature (Agar, 2002 - Stewart, 2003), the challenge for these approaches is to ensure that the over-report due to wetness of each device is sufficiently repeatable and distinct to enable some type adequate wet gas measurement.

### Type III Wet Gas Applications- having wetness levels in the range of $0.3$ XLM and greater

These wet gas meter applications address flows with Lockhart & Martinelli number greater than 0.3. In these applications types, typically the amount of oil, water and gas are the primary needs.

Type III wet gas applications are often viewed as a subset of the conditions typically addressed with partial separators and/or more general multiphase flow meters.

The use of these meters is generally in the realm of the offshore environment topsides and sub-sea and are cost prohibitive for general land use unless the system is high dollar value, typical sub-sea wet gas meters can approach 1 million dollar cost values!

## **MATHEMATICAL TERMS USED IN WET GAS MEASUREMENT**

Gas Volume (or void) Fraction.

$$GVF = \frac{V_{Gas}}{V_{Gas} + V_{Liquid}}$$

Where:

Q<sub>G</sub> = Gas Volumetric Flow-rate at flowing conditions, in ft<sup>3</sup>/sec

Q<sub>L</sub> = Liquid Volumetric Flow-rate at flowing conditions, in ft<sup>3</sup>/sec

(Equation 2)

Liquid Volume Fraction

$$LVF = \frac{V_{Liquid}}{V_{Gas} + V_{Liquid}}$$

Where:

Q<sub>G</sub> = Gas Volumetric Flow-rate at flowing conditions, in ft<sup>3</sup>/sec

Q<sub>L</sub> = Liquid Volumetric Flow-rate at flowing conditions, in ft<sup>3</sup>/sec

(Equation 3)

Superficial Gas Velocity

$$SGV = \frac{W_G}{\rho \cdot A}$$

Where:

W<sub>G</sub> = Gas Mass Flow-rate, lbm/sec

ρ = Density of Gas, lb/ft<sup>3</sup>

A = Area of Pipe, ft<sup>2</sup>

(Equation 4)

Lockhart & Martinelli No

$$X = \frac{QL}{QG} \sqrt{\frac{\rho L}{\rho G}}$$

(Equation 5)

Liquid Loading

$$LL = \frac{W_L}{W_G} \times 100\%$$

Where:

W<sub>L</sub> = Liquid Mass Flow-rate, lbs. /sec

W<sub>G</sub> = Gas Mass Flow-rate, lbs. /sec

(Equation 6)

Liquid Volume Fraction

$$LVF = \frac{QL}{QG + QL}$$

Where:

Q<sub>G</sub> = Gas Volumetric Flow-rate at flowing conditions, ft<sup>3</sup>/sec

Q<sub>L</sub> = Liquid Volumetric Flow-rate at flowing conditions, ft<sup>3</sup>/sec

(Equation 7)

Liquid Volume Fraction (LVF) also = 1 – GVF

(Equation 8)

Application	Bbl/MMSCF	Mass Ratio
Dry gas	0	0
Gas from separator	0-1	.75%
Gas from slug catcher	0-5	3.7%
Wet gas production	0-20	13%
Liquid / Gas production	>20	>13%

**Table 1. Typical Application Chart Showing Wet Gas Values**

## STANDARDS

Meter performance requirements in the wet gas arena are not covered fully in current measurement standards but an API recommended practice is available (No RP 85) that described the use of wet gas meters in an allocation system which was developed for a certain field condition in the Gulf of Mexico region. This is replaced now by the API Standard MPMS Chapter 20.3 multiphase-measurement that includes a section on wet gas.

Representation of the fluid, fluid velocities, types, measured volumes and regimes may not have been exactly defined or agreed in various commercial contracts across various regions of the world that may use different terminology to obtain a measurement result. This can add some confusion and sometimes many tough discussions between interested parties can ensue.

Current trends indicate approximate ranges of liquid/gas ratios found in most producing gas fields as having GVF's at around > 90-93% with maximum Lockhart-Martinelli number to maximum of 0.35 *XLM* (If the *XLM* number exceeds 0.35 this will indicate a slug flow condition).

The ASME published a wet gas standard completed ASME MFC Sub-Committee 19 (Wet Gas Metering)

All these documents make an good effort to detail some definitions to try to arrive at a common start point, and deal with 'wet gas' issues and fluid definitions thus:

## FLUID DEFINITIONS

Some definitions are given below for single-phase fluid streams (e.g. gas, water and liquid streams) and multi-phase fluid stream (e.g. wet gas streams and multiphase streams).

Unlike the downstream and transport and distribution businesses, for the upstream area it is not the case that all fluid streams are properly conditioned to one single-phase and indeed stay in one-phase over a large range of pressures and temperatures.

In the upstream area, the fluids are often un-stabilized, these fluids are what we experience in the wet gas arena and a pressure and temperature change (even a  $\Delta p$  across a measurement device or valve) may cause a phase change and change a single-phase fluid into a multiphase fluid. Accordingly, all definitions below should be referred to the operation ranges of temperature and pressure that occur in the system under consideration.

### Dry Gas (Treated Gas)

Clean dry gas (not necessarily only hydrocarbons but may contain other components such as  $CO_2$ ,  $N_2$ , etc.) where no liquid condensation is expected over the expected normal operating temperatures and pressures at the metering point. As an example, gas with a dew-point of  $-5^\circ C$  measured under conditions between 5 and  $10^\circ C$ .

### Equilibrium Gas (Separated at Dewpoint)

Equilibrium Gas is defined as separated gas that basically has no free liquids but may develop a small liquid content by changes in process conditions or meter/pipe-work interaction. Any process changes of the gas may cause a shift in the definition of the gas as wet or dry.

These changes may affect the GOR, GCR, the Lockhart-Martinelli parameter and the gas and liquid properties. Close to critical conditions, small changes may cause large variations in the liquid and gas fractions and in the fluid properties.

Care should be taken in meter selection so as not to cause additional impact on the line process conditions.

The measurement devices that can be used for equilibrium gas are similar to the devices mentioned for dry gas application. However, in the design, care should be taken in that, as soon as liquids start to be formed (e.g. due to pressure drop in the meter) the effect on the reading should be established.

Ultrasonic meters are increasingly being used for this service, and the following comments are relevant.

At present ultrasonic meters may not be suitable for measuring gas above 0.5% LVF (Liquid Volume Fraction) as the units may produce unstable readings.

Care should be taken in systems subject to carry over or liquid entrainment when the ultrasonic meter has a poor location. If the meter is too close to bends, valves or other obstructions, the resulting swirl / turbulence can seriously affect the accuracy of the mathematical techniques used to find the velocity profile and therefore the flow-rate.

If the operating temperature is too high there may be issues over the strength of the bonding material used in the manufacture of some types of Ultrasonic transducers.

Testing has shown some transducers may fail at temperatures in excess of 150°C or may be when there is a sudden pressure fluctuation. (an occurrence that can be common in production pipelines).

Other installation parameters or concerns that need care are that some signals read by the meter may be very susceptible to background noise from other components in, or close to the pipeline on some designs.

Work is however underway to develop ultrasonic meters for wet gas above current norms!

#### Wet Gas (two or three phase)

Any mixture of gas and up to about 10% by volume of liquid hydrocarbon and water. The mass ratio of gas to liquid varies significantly with pressure for a constant Gas Volume Fraction. A convenient parameter to indicate the wetness of the gas is the Lockhart-Martinelli Parameter.

#### Gassy Liquids (two or three phases)

Any mixture of hydrocarbon liquid and water at a pressure below its equilibrium pressure (bubble point) and where gas is present in the liquid mixture. This typically occurs inside a separator or where the liquid is exposed to a pressure reduction e.g. cavitation.

#### Gas-Oil (or Gas-Condensate) Ratio, GOR or GCR

The ratio of produced gas flow rate to the produced oil (condensate) flow rate. Generally the GOR or GCR is measured in standard units, e.g.  $\text{m}^3/\text{m}^3$  or Scf/bbl.

#### Gas-Liquid Ratio, GLR

The ratio of produced gas flow rate to the produced total liquid flow rate. Generally GLR is measured in standard units, e.g.  $\text{m}^3/\text{m}^3$  or Scf / bbl.

### **WET GAS RESEARCH**

A large amount of research has been conducted to determine the effect that wet gas flow regimes have on flow measurement devices. This research has been used to help to develop devices that can measure the gas and liquid volumes. To evaluate dry gas flow meters under wet gas conditions, a typical piping setup is commonly used. The apparatus consists of a reference gas flow meter positioned in a dry gas stream. A metered liquid injection point is positioned downstream of the dry gas measurement source. This is the point where liquid is introduced to the dry gas stream. The flow meter under test is positioned after the metered liquid injection point (Figure 2). Both the gas and liquid streams are measured individually before being combined.



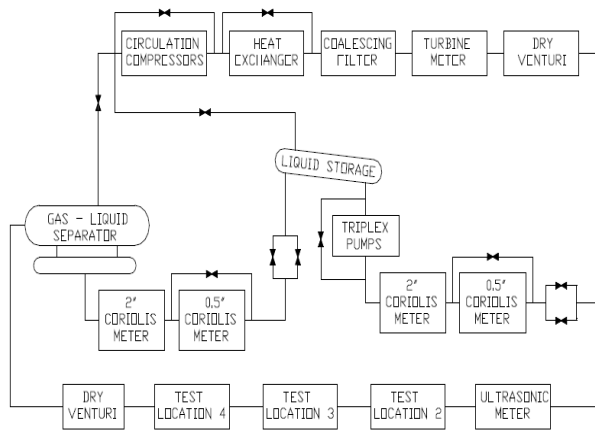

**Figure 2. Wet Gas Test Loop (CEESI Colorado)**

## WET GAS SAMPLING

The issue of hydrocarbon drop out at the sample point can be painful financially for the operator or gas transporter. The use of genie type or other types of membrane incorporated sample probes are useful in helping to minimize the liquid bleed over into the gas stream it is difficult to maintain the sample transportation chain and requires a lot of care an attention and field monitoring.

An example of this liquid ingress is the sampling of hydrocarbon components and liquid into the sample container that effectively boost's the BTU value to say 1450 from the norm for the gas at 1350, this change can mean that the loss of revenue due to bad L&U over millions of standard cu feet can be very high. Mayeaux (ISHM) in 2002 states that it is very difficult, if not impossible, to sample both the liquid and gas streams at the same time, with a single probe, without contaminating the sample! This is because the properties of the two streams are inherently different, and sample temperatures and pressures will affect the two phases in different ways. The primary difficulty encountered by many sampling methods is keeping the samples in their original form, once they have been withdrawn from the stream.

If the phases are allowed to commingle in the same container at the same operating temperature and pressure, for example, the higher molecular weight compounds in the gas phase will absorb into the liquid and the two-phase sample will become distorted.

Changes in either the temperature or pressure within the sample container will also result in composition changes between the phases, as shown in Figure 3.0, leading to possible errors in the analyzed heating value (i.e., BTU content) of the gas phase and the computed monetary value of the gas. If a two-phase sample is drawn, it must be kept at the temperature and pressure at which it was obtained, or sample distortion will occur.

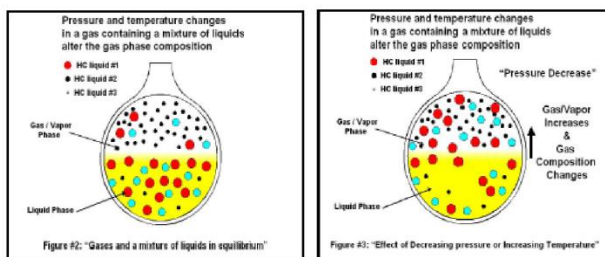

**Figure 3. Gas Sampling Challenges (2 phase flow)**

## EQUIPMENT AND TECHNIQUES FOR SAMPLING WET GAS STREAMS

One device works to separate the gas and liquid phases so that both phases can be sampled as accurately as is possible. Others are designed to preserve the composition of a gas sample as it is withdrawn from the flowing stream, ignoring the liquid phase.

These devices are sold commercially, but where possible, the information appearing here is taken from conference proceedings and published papers not sales materials.

One method of avoiding sample distortion is also described that does not rely on specific sampling devices.

### Probe Pressure Regulators

These devices are used to sample gas-only streams that are susceptible to condensation problems caused by a high hydrocarbon dew point. An example of a probe regulator and its installation is shown in Figure 4.0. In this approach, the probe withdraws a gas sample from the stream at the same pressure and temperature as the stream itself.

The sample then immediately passes through a regulator, where the sample pressure is reduced. A pressure reduction normally lowers the temperature of the sample through Joule – Thomson (Kelvin) cooling.

However, the probe's design uses the flowing gas stream as a heat sink to stabilize the sample temperature at the regulator and offset the cooling effect of the pressure reduction.

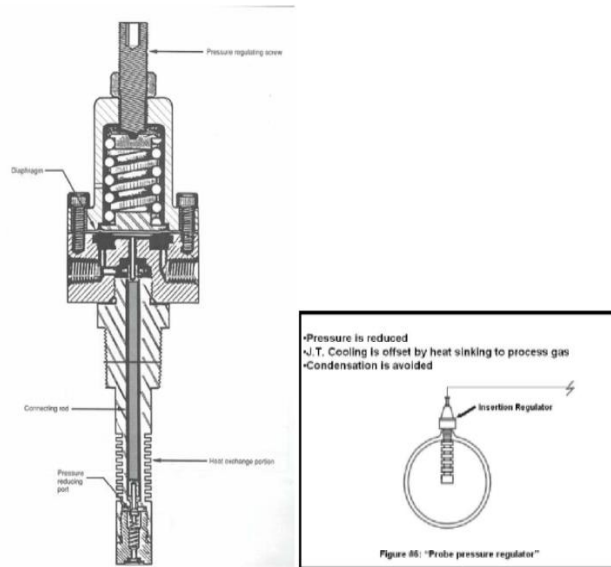

**Figure 4. Probe Pressure Regulator**

Several sampling equipment companies in the United States sell probe regulators. They are useful in instances where lowering the sample pressure at constant temperature will move the gas stream away from the hydrocarbon dew-point line and reduce the chances of sample condensation.

Probe regulators are used to improve the accuracy of water vapor determination.

However, if liquids are initially present in the gas stream, these devices will not work properly, and samples could be contaminated or distorted by liquid droplets that flash into the gas phase as the pressure drops.

### Phase-Separation Membranes

If liquids are initially present in the stream to be sampled, and only the gas stream is of interest, the liquid and the gas should be separated so that the gas can be sampled and analyzed correctly.

Phase separation membranes, shown in Figure 5 can be attached to sampling probes as one means to attempt to separate the liquid and gas phases inside the pipeline.

Some designs place the filter downstream of the regulator, while others separate the phases near the probe entrance, at the same pressure and temperature conditions as the pipeline flow. In the latter case, the gas sample may be controlled to help avoid condensation after it has been withdrawn from the flow stream. (Figure 5)

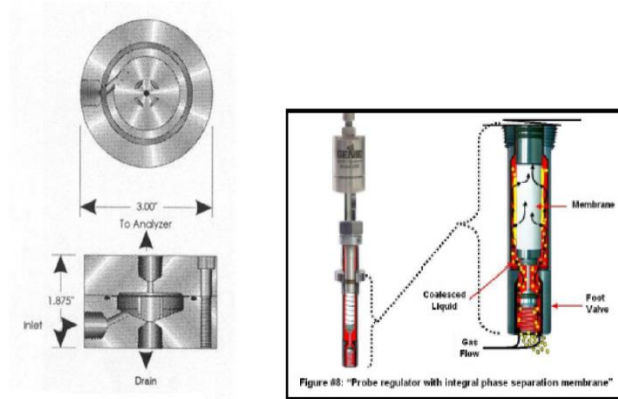

**Figure 5. Phase-Separation Membranes**

Two types of membrane filters are shown above:

Left: A “Liquid Eliminator”, membrane type liquid filter system, for mounting external to the probe.

Right: A “Genie Filter”, with membranes, both at the probe tip and external to the pipeline.

### Constant Pressure Sample Cylinders

A constant pressure sample cylinder, also known as a floating piston cylinder, is shown next in Figure 15.0. The cylinder is a tube with removable end caps that houses a moving piston. The end caps are removable to allow access to the piston, and also hold taps for valves, gauges or connections.

Some manufacturers advocate the use of constant-pressure sample cylinders to sample both phases of a wet gas stream without a separator.

If the cylinder can be prepared correctly, the pressure and temperature of the wet gas stream could be maintained as the sample enters the cylinder, and a phase change could potentially be avoided in the sampling process. In one proposed sampling method, the cylinder would be stored vertically for 24 hours, with the sample kept at the pressure and temperature of the wet gas stream.

The long storage time would allow liquids to settle to the bottom of the chamber. After 24 hours, a sample of the gas phase would then be drawn through the inlet at the top of the cylinder, with pressure and temperature held constant, next, the cylinder would be rotated 180 degrees and stored for another 24 hours.

The settled liquids would then be drawn from the bottom of the cylinder.

This method involves two key assumptions:

- (1) Both the cylinder and the sampling probe can sample the mixture uniformly.
- (2) The sample would be representative of both phases of the wet gas stream.

While studies were performed in an attempt to quantify the measurement uncertainty associated with samples drawn from dry gas streams using constant-pressure cylinders (Figure 6).

The writer is not aware of any similar performance assessments for wet gas streams unless separated gas is used \*et al Lawrence Wet Gas Sampling White Paper - Brazil Flow Measurement Workshop 2010.

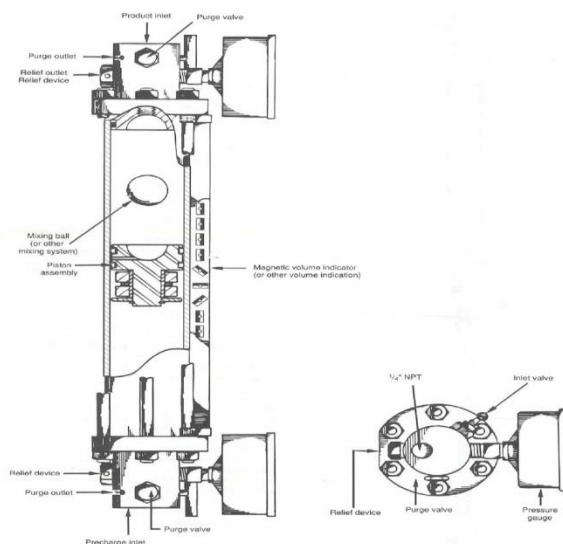

**Figure 6. Typical Constant Pressure Cylinder**

## **HEATING OF REGULATORS, VALVES, AND OF SAMPLING EQUIPMENT (VERY IMPORTANT)**

In this method, heat tracing is fitted to keep surfaces in contact with the gas stream above the hydrocarbon dew point temperature. This technique is commonly used to prevent condensation/dropout from the gas phase after it has been extracted from the flowing stream.

This technique also may be more costly than other methods to avoid gas phase condensation, particularly if the sampling location is far down-stream of a separator. The method must also be used carefully to avoid sample distortion.

For example, if liquid droplets are ingested into a sample of the gas phase and the sampling equipment is heated, the liquid may vaporize and distort the composition of the gas phase sample. However, if heat is applied to a gas immediately upon exiting a separator that is effectively separating the gas and liquid phases, the gas composition will remain unchanged.

Some experts in the natural gas industry advocate the technique of combining heating with a sample separator, while others cite the potential for large errors from sample distortion. Clearly, the technique must be used carefully, but may provide representative samples of the gas phase of a wet gas flow in the low *XLM* range Type 1 region.

## **SPOT SAMPLING**

One important point is the bottle temperature, this is particularly important when taking samples from Upstream interconnects.

Newer technologies are entering the market place each year however a uniform test method must be developed to offer the end user the chance for comparison between these types of metering devices.

Spot sampling methods as per GPA 2166 are important as a starting point to try to collect a rich gas/wet sample.

The difference between an unheated sample bottle and heated during a spot sample collection can be a source of measurement error in the BTU value (composition) of the gas.

The following chart shows the difference between heated and non-heated spot sample bottles, this is real data a local operator produced.

Rich gas can change to liquid in the cylinder if the temperature drops.  
This shows the effect of liquid droplets that fall out in cold cylinders.

	BTU	Density	C5+	GPM
Location 1 Warm Cylinder	1197.14	0.7066	1.022	4.585
Location 1 Cold Cylinder	1208.17	0.7128	1.264	4.752
Diff %	0.92%	0.88%	23.68%	3.64%
Location 2 Warm Cylinder	1249.37	0.738	1.284	5.838
Location 2 Cold Cylinder	1251.73	0.7395	1.368	5.855
Diff %	0.19%	0.20%	6.54%	0.29%
Location 3 Warm Cylinder	1248.12	0.7374	1.134	5.888
Location 3 Cold Cylinder	1260.67	0.746	1.518	6.001
Diff %	1.01%	1.17%	33.86%	1.92%

**Table 2. Heated Versus Non-heated Spot Samples**

## CONCLUSION

Wet Gas measurement is a complicated subject that requires forethought in measurement applications it is usually at the cutting edge of technology. As more work is done in this field ideas that were valid 10 years ago are now found to be changed as more is discovered and test work completed.

The advent of metering applications where hydrate formation is possible must have a safety review incorporated to make sure that not only measurement but safety issues are dealt with.

The BTU effect on natural gas transportation companies caused by wet gas streams and its sampling is a challenge that requires constant monitoring of the streams being sampled equipment must be in top conditions, maintenance taken to a higher level and also care and attention taken when handling the sample itself!

## REFERENCE MATERIALS

Kegel, T.M, "Wet Gas Measurement", 4th CIATEQ Seminar on Advanced Flow Measurement, 2003

Lawrence PA & Steven R, "Research Developments In Wet Gas Metering with V-Cone Meters", NSFMW, 2003

M Nored /D George, "A Review of the State and Direction of Methods for Gas Sampling", 2003

Kinney J, "ISHM Class # 1320 Wet Gas Measurement", ISHM, 2006

ISO TC 193WG, "1.0 Allocation Metering in the Upstream Area (white paper)", 2006

Lawrence PA, "ISHM Class # 1320 Wet Gas Measurement", ISHM, 2006

Lawrence PA, "ISHM Class # 1320 Wet Gas Measurement", ISHM, 2015