

FLOW CALIBRATING ULTRASONIC GAS METERS – CONSIDERATIONS AND BENEFITS

Joel Clancy

CEESI Iowa
2365 240th Street
Garner, IA USA

Introduction

The primary method for custody transfer measurement has traditionally been orifice metering. While this method has been a good form of measurement, technology has driven the demand for a new, more effective form of fiscal measurement. Ultrasonic flowmeters have gained popularity in recent years and have become the standard for large volume custody transfer applications for a variety of reasons. Most users require flow calibrations to improve meter performance and overall measurement uncertainty. The latest revision of AGA Report No. 9, *Measurement of Gas by Multipath Ultrasonic Meters, Second Addition [Ref 1]*, now requires flow calibration for ultrasonic flow meters when being used for custody transfer applications.

What considerations then, should be taken when choosing to flow calibrate an ultrasonic flowmeter? What are the benefits to the user? What should a user expect from a flow calibration? What kind of performance should the customer expect or accept from an ultrasonic meter? What are the diagnostic capabilities inherent in an ultrasonic meter? These areas, as well as others will be explored and considered.

Pre-Calibration Inspection and Meter Installation

Upon receiving the ultrasonic flowmeter at the calibration facility, a thorough inspection is started. Ultrasonic meters are often very large with attached electronic instruments so the inspection of the ultrasonic flowmeter begins before it comes out of the box. A damaged shipping container indicates that the meter may have visible damage or damage to electronic components that will be harder to find. Open the crate and inspect the electronics. Ensure that all electronic boards are securely fastened to the junction box that houses the electronics. Look for any signs of damage or any loose parts or fittings. Inspect the meter body. Ensure that the transducers are not damaged. Ensure all cables are securely fastened.

When installing the meter in the piping system, inspect the holes where the pressure taps penetrate the meter body on the inside surface. Any burrs or protrusions on the pressure taps can create pressure reading errors and must be removed prior to calibration. Ultrasonic flowmeters are often sold with upstream and downstream spool pieces. There may be identification stamps on the meter and accompanying spool pieces, make sure the identification numbers match. The meter and spool pieces may have alignment pins. Check the alignment as it is not unusual to find the pins do not provide good alignment. Spool pieces may come separately from a different supplier. In this case ensure that the internal diameter of the spool pieces matches the internal diameter of the meter. Drawings typically accompany the meter and spool pieces. Assemble the meter parts as shown in the drawings. Flow conditioners sometimes fail when first used. Inspect the flow conditioner to ensure the manufacturing and assembly is complete. Some flow conditioners need to be pinned as they can move around inside the pipe when installed. It is important that all upstream components that can affect the flow conditions at the meter remain exactly the same in use as they were during the calibration.

Meters that have been in use in the field are often recalibrated. These meters do not have original shipping containers and are often partially disassembled for shipping. Inspect the cables carefully ensuring all cables are still connected to the meter and that no damage has occurred. Inspect the inside surfaces of the meters. There is often a build-up of contaminants. Ensure the pressure taps are clear. The customer may want the meter calibrated in the condition it arrives in, referred to as an “As Found” calibration, then cleaned and recalibrated clean, referred to as an “As Left” calibration. In the past few years, more data has become available on how well ultrasonic flowmeters perform with thick layers of contaminants on the transducers and pipe walls. Any difference in performance of the meter between the “As Found” and “As Left” calibration may be very useful to the customer.

Once the meter and spool pieces have been installed in the test section the instrumentation can be installed and the meter can be powered up. Pressure and temperature transmitters are now installed. Dual instrumentation is preferred. When dual instrumentation is used any differences in readings can be identified quickly allowing the calibration to proceed smoothly. The communication lines are then connected to the meter. The most common communication options are RS-485, RS-232, or Ethernet communication. One communication output is used to communicate flow and meter status information to a computer running software provided by the manufacturer. Another output is also connected to the meter. This output is a second flow signal from the meter. The second output may be an RS-485 output or the meter may produce a frequency output, which is proportional to flow passing through the meter. If an older meter is received from the field for recalibration it may require

some communication switch changes to allow communication with the calibration facility. These changes are well documented and are returned to their initial settings once the calibration is complete.

The location of the thermowells should be noted. AGA Report No. 9 discusses the appropriate placement of a thermowell stating 2 to 5 pipe diameters downstream of the ultra-sonic meter. In the case of a bi-directional meter, AGA 9 calls for a thermowell placement of 3 to 5 diameters from either ultrasonic meter flange face. Although thermowell placement is defined in AGA 9, some users elect to choose a different location for their thermowell(s). Caution should be taken here. Often thermowells are placed upstream of a flow conditioner. The pressure drop created by the flow conditioner also creates a corresponding temperature drop known as the JT (Joules Thompson) effect. You have, therefore, a different temperature at the meter than is being recorded by the temperature transmitter. Proponents of this type of temperature measurement design look to the design and expense that has gone into the conditioning of the flow. Flow conditioners can help produce a good, symmetrical flow profile; given the upstream flow conditions are not extremely severe. A great deal of thought, design and cost goes into ensuring a good, uniform flow profile, before the gas reaches the meter. If the thermowell is placed at a position downstream of the flow conditioner, the profile becomes slightly skewed. However, research has shown that placing the thermowell directly upstream of the meter does not adversely affect meter performance. This technique also ensures accurate temperature measurement at the meter. Many users, therefore, place the thermowell at 3 to 5 diameters upstream of the meter.

Meter Calibration

Test section pressurization, leak check, and pre-flow are now performed. As the meter body pressurizes, dual pressure instrumentation is checked for good agreement. Pre-flow is generally conducted at 60 to 80% of the meter capacity. Pre-flow typically lasts for 15 to 30 minutes. The pre-flow allows the meter and test section piping to come to the flowing temperature of the gas. Dual temperature instrumentation is checked for good agreement. During pre-flow, several piping and instrumentation conditions are checked. Flow conditioners are often a source of flow noise. The amount of noise being generated by the flow conditioner is monitored during pre-flow. Any unusual mechanical noises may be an indication that the flow conditioner is coming apart or vibrating violently. Installing a thermowell too close to a flow conditioner can cause thermal well vibration. This installation can produce several problems. This vibration can cause problems for the ultrasonic meter. The introduction of noise inhibits the meter's ability to function properly. The thermowell vibration also creates a heating effect that will produce a temperature measurement error at the ultrasonic. In addition to temperature measurement errors, this vibration can cause the thermowell to fail over time. When performing pre-flow, the performance of all the ultrasonic transducers is monitored to ensure there are no chord failures. Unusual signals can be produced from a variety of problems to include a bad set of transducers, incorrect wiring, etc.

Once pre-flow is finished, the calibration begins. The flow is taken up to the highest flow rate requested by the customer. If no flow-rates have been specified by the customer, the flow-rate is taken to the maximum flow-rate suggested by the manufacturer. At the high flow-rate there may be enough flow noise to cause chord failure. That is, the flow noise is of a sufficient level to weaken the signal received by the meter. It is important to monitor the system carefully when increasing flow to the highest flow-rate. If any components are going to fail then this is the time when failure is most likely to happen. Any unusual noises or large changes in noise may indicate that a system component is experiencing failure.

When flow at the highest flow-rate has been established, the calibration system is allowed to stabilize. Ultrasonic meter calibration systems may be composed of large piping systems with a considerable amount of volume between the standards used to accurately measure flow during the calibration and the ultrasonic meter being calibrated. It is important that any pressure fluctuations that may be present in the system due to changes in flow-rate are allowed to dissipate. When stable flow conditions have been observed for an adequate length of time, calibration data can be taken from the ultrasonic meter being calibrated and the calibration system. Several data points may be taken at a single flow-rate. The number of data points may be specified by the customer, or it may be left to the judgment of the calibration system operator.

Data may be acquired using two separate computer systems. One system will be running software supplied by the manufacturer that will interrogate the meter while a data point is taken and another system will acquire data from the calibration system. Typically, these two systems acquire data during the same time period.

Obtaining the calibration log file from the meter's software data logs can prove to be an important tool once the meter is put into service. This initial log collected at the time of the calibration can provide information such as speed of sound, or gain level to limit ratios on a chord by chord basis to name a few. This initial log file collected at the time of the flow calibration is often referred to as the meter's baseline or fingerprint. When collecting logs throughout the life of the meter, the baseline logs can be used as a reference. Any deviations from the chord ratios or other diagnostics observed at the calibration can be used as a way to troubleshoot potential problems with meter performance.

General Description of a Calibration and Calibration Systems

Calibrations are performed by placing a flow standard in line with the ultrasonic flowmeter being calibrated. The flow standard is used to accurately measure flow and has been calibrated using standards that are traceable to NIST or some other national standard. As long as there are no leaks in the system between the standard and the meter being calibrated it can be assumed that the two meters are passing the same amount of flow. There may only be one standard or there may be many that can be placed in parallel in the flow stream to produce a wide flow-rate range.

There are two basic types of calibration systems. Drawing 1 shows a calibration system on an existing natural gas pipeline. When the large valve on the pipeline is closed slightly a differential pressure across that valve is produced. The differential pressure across that valve provides a motive force to push flow through the calibration system. As the main pipeline valve is closed further, more flow is pushed through the calibration system. In this manner a wide flowrate range can be passed through the calibration system allowing the calibration of a wide range of meter sizes. At very low flow-rates, fine flow control can be accomplished by throttling with a smaller valve in-line with the meter being calibrated.

There are advantages to this type of system. Because the pipeline is passing flow constantly, very long data points or many data points at a single flow-rate can be taken. The meter being calibrated is flowing under actual pipeline conditions. There are potentially many gas chromatograph outputs available to monitor gas composition so a stable gas composition can be assured. Because there are gas chromatographs placed at metering stations along the pipeline any variations in gas composition can be seen well in advance as the gas proceeds through the line. This type of system can hit very high flow-rates allowing calibration of the largest ultrasonic meter sizes.

The disadvantages of this type of system vary. The pressure drop at a given location will have limitations. This does not affect ultrasonic calibrations but can be a consideration when calibrating meters that need to create a pressure drop. The calibration system has to operate at the pressure in the pipeline. This means that a meter to be used in a low-pressure system may have to have a flange with a higher pressure rating installed temporarily for the calibration. The quality of the data may be affected by the pipeline stability. If the line pressure is rising or falling, it may not be possible to acquire data. Typically however, pressure, temperature and gas composition are quite stable.

The second type of system typically used is shown in Drawing 2. This type of system is referred to as a pressurized loop. Prior to flowing, the loop is pressurized with gas to the desired flowing pressure. Flow through the system is created by a compressor that must run continuously while calibrating. Flow control valves can be placed in the system for flow control. Heat exchangers in the system allow some temperature control.

A pressurized loop system also has certain advantages. The flow in pressurized loop systems can be precisely controlled. The temperature in a pressurized loop can be varied over a limited temperature range allowing the effects of different flowing temperatures to be investigated. The composition of the flowing gas can be varied by injecting different components into the loop.

The disadvantages of a pressurized loop calibration system include high operating expenses. This is because the compressor(s) must be operating continuously. The suction pressure on the compressor must be maintained above some minimum value, which places a limitation on the differential pressure across the loop. This limitation, as well as limitations to compressor capacities and line size is typically the primary contributing factors to flow limitations on a pressurized loop based calibration system. [Ref. 2]

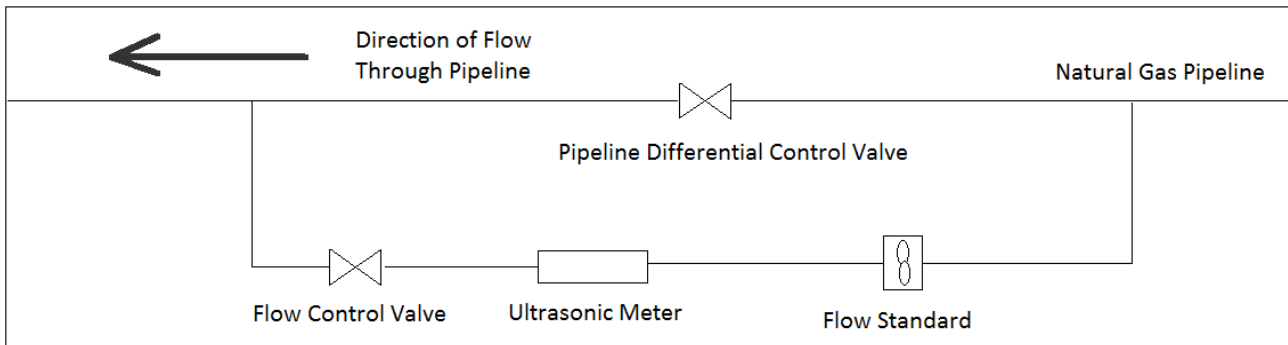

Drawing 1. Flow Through (pipeline) Based Calibration Facility

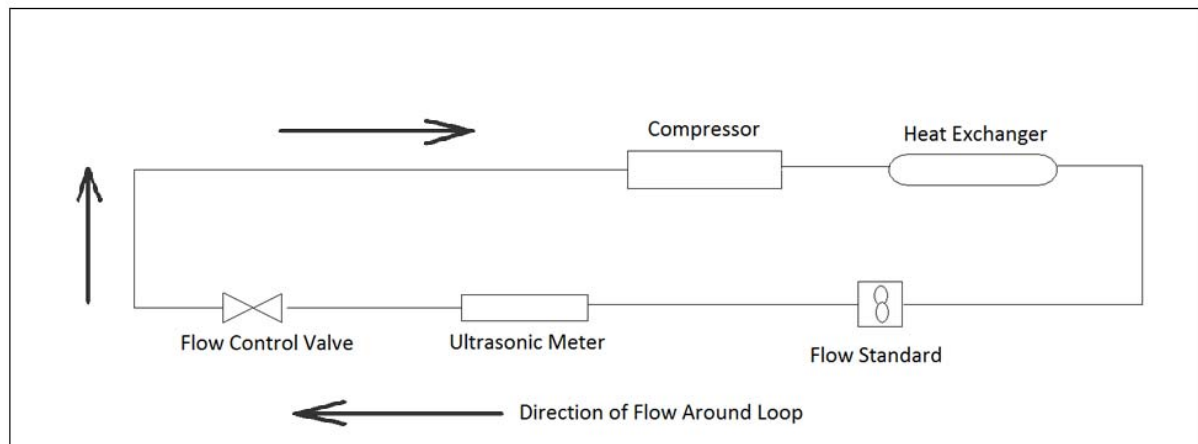

Drawing 2. Loop Based Calibration Facility

As Found, As Left and AGA 9

Although not a standard, AGA Report No. 9 is a useful tool for the end user to use as a basic guideline for ultrasonic meters. While most users use this as a guideline for acceptance criteria, not all use this as hard and fast pass-fail criteria. Many users look at the “as-left” performance of the meter.

Observe the following example of two twelve inch ultrasonic meters: Meter “A” (Table 1, Figure 1) meets AGA 9 criteria both in linearity and in offset (% error). Meter “B” (Table 2, Figure 2) does not meet AGA 9 criteria in offset; however it does meet the linearity criteria. Note the “as-left” results of meter A. This example uses the AGA 9 Flow Weighted Mean Error (FWME) adjustment. Applying this adjustment to the meter does not correct for the non-linearity of the meter and therefore makes the meter read slow at the high end and fast at the low end. Conversely, Meter “B” is quite linear. The as-left adjustment allows this meter error to be reduced to less than 0.04%, after the FWME adjustment is applied, throughout the entire range. While Meter “B” does not meet AGA 9 criteria, this meter exhibits better performance after adjustment.

AGA Report No. 9 Calibration Factor Calculation Example

A 12-inch ultra-sonic flowmeter is to be calibrated with a maximum flow-rate of 100 ft/sec. The customer has requested that calibration data be taken in compliance with AGA Report No. 9 with a minimum flow-rate at a meter velocity of 1 ft/sec. The calibration facility operator sets up the calibration plan shown in Table 1.

Velocity ft/sec	% Error As Found	% Error As Left	% Full Scale	% F.S x Error
100	-0.69	-0.19	100%	-0.69
70	-0.5	0	70%	-0.35
50	-0.4	0.1	50%	-0.2
30	-0.32	0.18	30%	-0.096
20	-0.3	0.2	20%	-0.06
10	-0.26	0.24	10%	-0.026
4	-0.2	0.3	4%	-0.008
1	-0.01	0.49	1%	-0.0001
		Sum =	2.85	-1.4301

Table 1. 12-inch Meter “A” Results Summary

From the above results, a FWME can be calculated. Utilizing the data from the above table, the Percent Full Scale must be determined. This value is calculated as follows.

$$PercentFullScale = \frac{IndicatedFlowrate}{MaximumFlowrate} \times 100 \quad (\text{Equation 1})$$

Now the percent full-scale values are multiplied by the percent error (as found) values. This leaves the resulting value in the percent full-scale times error column in table 1. The percent full-scale and percent full-scale times error columns are then summed. With these summed values, a FWME can be calculated. This is done by dividing the summed percent full scale, times percent error value, by the summed percent error value. From table 1, we calculate the following.

$$FWME = \frac{-1.43}{2.85} = -0.50175 \quad (\text{Equation 2})$$

Once the FWME is derived, a calibration factor can be computed. The calibration factor (or calibration correction) is then entered into the meter software and the meter is adjusted electronically. The calibration factor is calculated as follows.

$$CalibrationFactor = \frac{100}{100 + FWME} = 1.0050 \quad (\text{Equation 3})$$

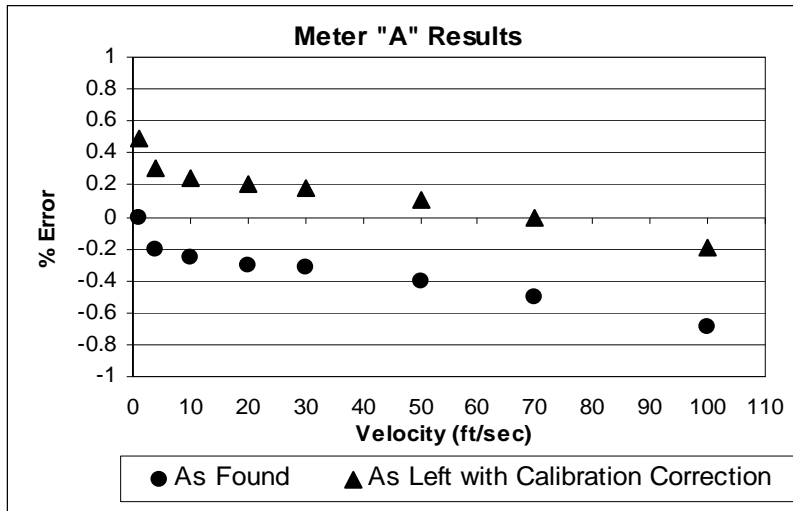

Figure 1. Meter "A" Results with Correction Applied

Velocity ft/sec	% Error As Found	% Error As Left	% Full Scale	% F.S x Error
100	0.75	0.03	100%	0.75
70	0.71	-0.01	70%	0.497
50	0.72	0	50%	0.36
30	0.74	0.02	30%	0.222
20	0.71	-0.01	20%	0.142
10	0.72	0	10%	0.072
4	0.74	0.02	4%	0.0296
1	0.77	0.05	1%	0.0077
		Sum =	2.85	2.0803

Table 2. 12-inch Meter "B" Results Summary

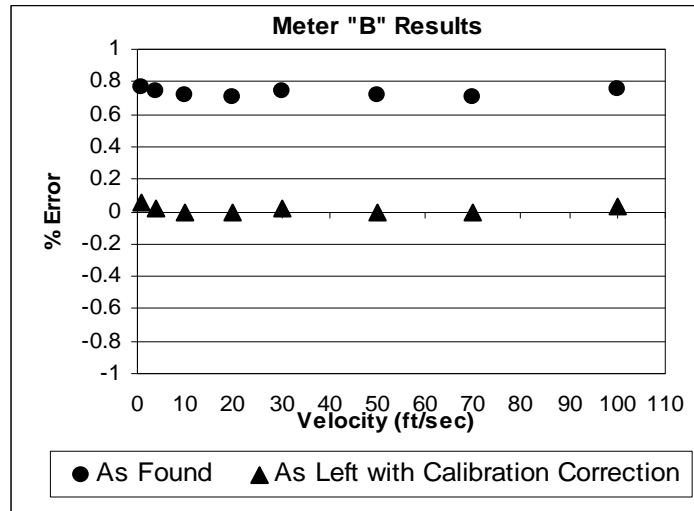

Figure 2. Meter “B” Results with Correction Applied

AGA 9 acceptance criteria are a good tool for the user to utilize. Many custody partners will agree to use these criteria as a basis for “pass or fail”, in order to have an accepted agreement prior to flow calibrating the ultrasonic meter. However, the above example shows why some users may choose to accept a meter that does not meet AGA 9 criteria.

Alternative Methods for Meter Adjustment

AGA 9 also allows for alternative methods for adjusting the meter. One popular method that is being used by several ultrasonic meter manufacturers is a second order polynomial curve fit. This method would better fit or adjust meter A in the previous example. Note the below results (Table 3, Figure 3) showing the same meter and it’s new as-left condition utilizing a second order polynomial curve fit. This linearizes the meter quite well, leaving the meter error at less than 0.04% through the entire range.

Velocity ft/sec	% Error As Found	% Error As Left	% Full Scale	% F.S x Error
100	-0.69	-0.03	100%	-0.69
70	-0.5	0.03	70%	-0.35
50	-0.4	0.03	50%	-0.2
30	-0.32	0.02	30%	-0.096
20	-0.3	-0.01	20%	-0.06
10	-0.26	-0.03	10%	-0.026
4	-0.2	-0.03	4%	-0.008
1	-0.01	-0.03	1%	-0.0001

Table 3. Meter “A” with 2nd Order Polynomial Adjustment Applied

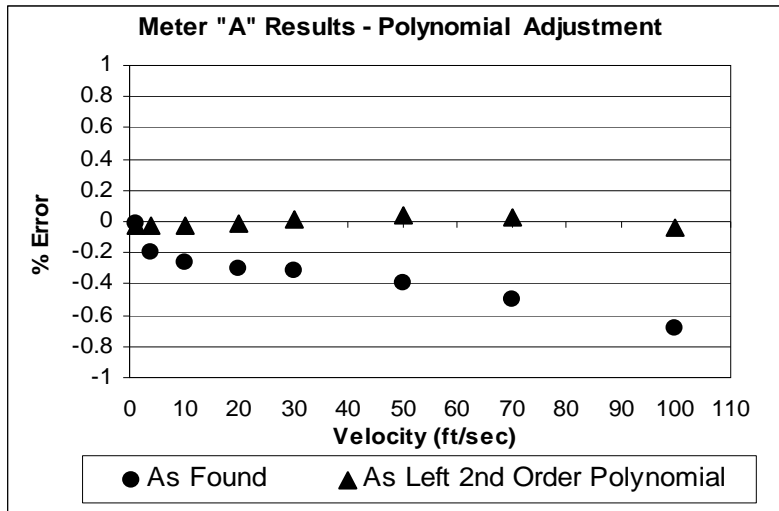

Figure 3. Meter “A” with 2nd Order Polynomial Adjustment Applied

Another method being used by several meter manufacturers is a multi-point correction technique. This method allows the user to adjust the meter at the time of the flow calibration, such that all points theoretically fall directly on the 0.0% error line throughout the entire range (Table 4, Figure 4). This adjustment technique is the most widely used today. This same technique can also be incorporated in the user’s flow computer, however, this typically does not allow for a verification check after such adjustments have been made; where the multi-point correction coefficients installed directly in the meter allow for a verification checkpoint to be run at the time of the flow calibration. Note Figure 4 below showing a multi-point correction adjustment.

Velocity ft/sec	% Error As Found	% Error As Left	% Full Scale	% F.S x Error
100	-0.69	0	100%	-0.69
70	-0.5	0	70%	-0.35
50	-0.4	0	50%	-0.2
30	-0.32	0	30%	-0.096
20	-0.3	0	20%	-0.06
10	-0.26	0	10%	-0.026
4	-0.2	0	4%	-0.008
1	-0.01	0	1%	-0.0001

Table 4. Meter “A” Results with Multi-Point Adjustment Applied

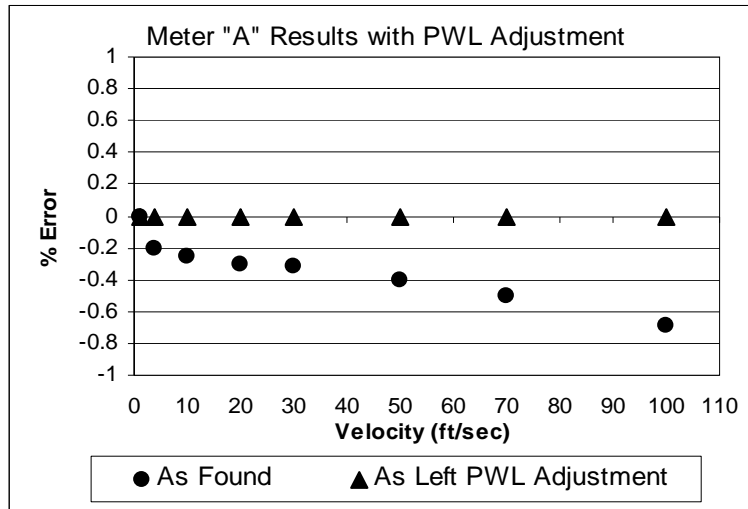

Figure 4. Meter “A” Results with Multi-Point Adjustment Applied

Meter Rangeability and Calibration Point Selection

Depending upon the application and station throughput, users may choose to install one large ultrasonic meter, two mid-sized meters, or several, small ultrasonic meters. This is true for both new meter stations, and stations being retro-fitted with ultrasonic flowmeters.

Note one example where nine, 12-inch orifice meter runs were replaced with one 30 inch ultrasonic flow meter. This decreased the user’s maintenance costs considerably. For a new meter station, with the same throughput, this would decrease costs for pressure, temperature, and differential pressure transmitters. Additionally, this station requires less flow computers, valves, and piping to name a few. Proponents for such an installation point to these areas as the benefits of installing one, large volume meter.

The above installation does have disadvantages, however. Having one, large volume meter can make meter re-calibration difficult. Additionally, many users feel that installing a single meter would be “putting all your eggs in one basket”. If the meter becomes inoperable, the pipeline’s measurement would be adversely impacted if a second meter was not available for measurement. Because of this philosophy, some users would, for example, choose to install two 16 inch meters for their fiscal measurement. This would enable the user to have a second meter in the event that one might fail. It also allows for ease in maintenance, such as pulling the meter and meter run for cleaning or sending off for re-calibration.

The above examples can and do drive where the meter will operate within its range. Once again, depending upon station design, users should flow calibrate the meter where they expect to operate this meter. In the case of the 30 inch meter above, the user, knowing the meter would not be used below 10 ft/sec, chose to calibrate down to 5ft/sec. Many users are pushing the lower limits of ultrasonic meters in an effort to reduce the costs of installing secondary low-flow custody meters (such as a turbine or PD meter). Because of this, and improved curve fitting methods, many users are flow calibrating down to 1 or 2 ft/sec with expectations of operating at that low end for short periods of time. Due to potential thermal gradients and meter repeatability at this low operating range, the meter’s uncertainty is reduced, but for many users the tradeoff is beneficial, as the costs of installing a second low flow meter are not incurred.

Data is typically taken at a minimum of six or seven flow-rates. AGA Report No. 9 specifies flow-rates of $0.025q_{max}$, $0.05q_{max}$, $0.10q_{max}$, $0.25q_{max}$, $0.50q_{max}$, $0.75q_{max}$, and q_{max} . Additional data points may be requested at specific flow-rates by the customer if the meter is to be used in a specific flow-rate range. Once the initial calibration is complete, the appropriate adjustment(s) should be applied electronically to the meter. After the adjustment has been made, a verification calibration is typically conducted. The user typically chooses between one and three verification points to be run in order to ensure the adjustment was applied correctly and works appropriately.

Post Calibration Considerations

Once the calibration is complete, data should be reviewed by the user. Once the data has been accepted, a security jumper is set (if available) to set the meter into a “read-only” mode. This security feature inhibits any accidental (or intentional) changes that might be made to the meter’s metrology configurations.

Shipping instructions should be provided to the calibration facility in order to ensure proper and timely delivery to the end location. The meter and its associated piping should be end capped and sealed such that no debris or dirt can enter the meter and/or meter tube internal section.

Once the meter is installed in the user’s pipeline, a communications check should be performed. Ensure proper responses to the flow computer. A log file should be collected for your records. This data should be reviewed paying specific attention to individual transducer path data. If the meter is under flowing conditions, this log file should be compared to the meters baseline logs taken at the time of the flow calibration. Some users choose to take daily logs for the first week to add to the meter’s baseline data. This allows for several sets of baseline data to be collected while the meter is still typically in a new and clean condition. Most users will then take monthly logs. These logs can then be trended with previous logs to ensure path ratios are remaining constant and that no anomalies have occurred with other log file data. During the course of monitoring these data, differences may be noted. For example, a speed of sound difference may be observed. Often, this deviation from the trend may not be due to problems with the ultrasonic meter. Frequently, the user may instead discover problems with pressure or temperature measurement, or a problem with the gas chromatograph. If these instruments are checked and known to be in proper working condition, further investigation should be conducted by reviewing the meter’s log files. Specific attention should be given to individual path speed of sound, gains, performance, and signal to noise ratios to name a few. If any of these differ from recent trends in the meter’s performance, this may point to potential problems with the ultrasonic meter. Your company’s ultrasonic measurement specialist and/or the meter manufacturer should be consulted if an abnormality is discovered.

Improved Diagnostic Capabilities

In more recent years, enhancements in both ultrasonic meter firmware and software have allowed for improved diagnostics. These enhancements have given the user a more “user friendly” form of diagnosing problems with the meter in several areas.

Such problems as dirt buildup on the wall of the meter or the transducer face can now be detected by using the manufacturer’s diagnostics software. Debris caught in the flow conditioner upstream of the ultrasonic meter can also be detected. Deviations in individual path speed of sound are more easily detected by the user by using these diagnostic tools. Elevated gains on any given path can point to problems with the ultrasonic meter.

Another diagnostic tool that continues to be used frequently is a calculation of the meter’s profile factor. One manufacturer calculates this value by taking the average axial path flow velocities, divided by the average swirl path flow velocities. Another manufacturer calculates the profile factor by taking the average inner path velocities, divided by the average outer path velocities. This is an important tool that can be looked at quickly to see if there is a variance from the historical profile factor, or variance from the time of flow calibration. Deviation in this value can prompt the user to begin looking at further diagnostic data to see if there are variations present elsewhere. Monitoring the profile factor from the meter can prove to be a very useful tool; however, caution should be used here. If there is a sudden change in flowing velocity on a single path, the profile factor value will deviate from its historical value. However, if the flow velocity changes in two or more paths at the same time, the profile factor calculation can mask such a change. To monitor a change on an individual path, it is necessary to look at the individual path velocity ratios. This is done by taking an individual path velocity and dividing it by the meter’s average velocity. Other key diagnostics are symmetry, signal to noise ratios, and performance to name a few.

Summary

Today’s users continue to demand improved performance on measurement. Improved technology and the wide-spread use of ultrasonic metering has allowed enhanced performance and improved overall measurement uncertainty. A key part of this equation is the flow calibration of ultrasonic meters being used for fiscal measurement. A knowledgeable user should have a good understanding what to look for during the calibration process, as well as options available with respect to operating range, number of data points, and meter rangeability. Once operational, the user should use the diagnostic tools available to monitor the health of the meter. Improvements in software and firmware have allowed for an advanced level of meter diagnostics.

References

1. AGA Report No. 9, *Measurement of Gas by Multipath Ultrasonic Meters*, Second Addition, April 2007
2. William Johansen and Joel Clancy, *Calibration of Ultrasonic Flowmeters*, International School of Hydrocarbon Measurement, May 2003