

LIQUID MEASUREMENT STATION DESIGN with NGL CONSIDERATIONS

Michael P. Frey
Area Flow Solutions Manager
Cameron International Corporation, a Schlumberger company
3250 Briar Park Blvd.
Houston, Texas USA

Introduction

There are many factors that must be considered in order to properly design a liquid measurement station. While many of the components of measurement stations are similar, the criterion that determines the equipment to utilize for a given application or product can vary significantly from project to project. This paper will address the most common applications in the liquid hydrocarbon industry for large volume product measurement as it pertains to custody transfer applications. Custody transfer measurement includes accurate quantity measurement through the use of metering, though equally important is accurate quality measurement through the use of quality and sampling equipment. These custody transfer and/or fiscal metering stations consist of mechanical components and instrumentation on a skidded system along with simple to complex supervisory control systems with flow computers, programmable logic controllers (PLCs) and a human machine interface (HMI) with customized programming to achieve the required measurement goal.

Applications

Liquid measurement applications can be as simple as a single meter with an electronic totalizer in the upstream production market to complex multi-meter run skidded system with motorized valves, flow control with automatic proving and complex control systems in the midstream and downstream markets. The control systems are capable of generating alarms, reports, selecting meter factors based on the variables of product density, viscosity, flow rate and remote communications from the end user central control room. Applications vary as widely as the number of liquid hydrocarbon products that are metered today.

Crude oil and natural gas are the most widely metered hydrocarbon products today. With the rise of the unconventional recovery methods in the oil sands of Alberta and in the shale plays throughout North America, crude oil metering has expanded beyond the traditional LACT unit from production to pipelines for delivery to refineries. The methods of transporting crude oil have grown significantly in the last five years with truck, railroads, waterways, new pipelines and converting natural gas pipelines to liquid service. This increase has also increased the requirements of measurement systems for loading and unloading these vessels and pipelines. In addition to the onshore expansion, offshore applications have also increased with the deep-water platforms and the unique challenges these applications present due to strict limitations on space and weight. Floating production, storage and offloading (FPSO) vessels also require accurate metering and sampling with limited footprint and weight requirements.

Crude oil is not the only hydrocarbon product where liquid meter stations are needed. Refined products such as gasoline, diesel and aviation fuels that are characterized as in the downstream market segment also require custody transfer level measurement. These station designs are very similar to crude oil stations with the exception that these are cleaner products and typically have a consistent density and viscosity characteristic.

NGLs, LPG, LNG

In addition to the refined products and crude oil, metering stations for natural gas liquids (NGLs), liquefied petroleum gas (LPG), and liquefied natural gas (LNG) are also required in the hydrocarbon industry. Some of these products can be difficult to meter and special consideration is needed when designing these measurement stations. NGLs are of particular interest in today's measurement industry as they are a mixture of varying percentages of components with differing molecular structures. For accurate NGL measurement it is necessary to determine the volume of the product(s) as well as the mole percentage of each component in order to determine the true value of the measured product. NGLs are derived from natural gas and consist of ethane, propane, butane and the components of natural gasoline. Metering systems for NGLs require volumetric measurement (turbine meter or liquid ultrasonic meter) with inferred mass from a densitometer, or direct mass measurement utilizing Coriolis meters. Proper sampling techniques and the use of a gas chromatograph are required for accurate NGL measurement.

Industry Standards and Specifications

The American Petroleum Institute's Manual of Petroleum Measurement Standards (MPMS) consists of twenty two chapters each with multiple sections covering nearly every aspect of hydrocarbon measurement. The MPMS also consists of technical references and recommended practices for subject matter important to the industry, though not part of a published standard.

In addition to the MPMS, the industry also utilizes standards published by the International Standards Organization (ISO) which closely reflect the API documents. Other industry standards, codes and practices are detailed in the American Society of Mechanical Engineers (ASME), American National Standards Institute (ANSI), and American Standards for Testing of Materials (ASTM) and other international standards documents. Many countries have weights and measures standards as well, i.e., Measurement Canada.

Most major oil and gas companies have their own specifications and requirements that must be followed in addition to the published standards noted above. When providing measurement stations for the international market many countries require adherence to their government weights and measures doctrine which often require specific type testing for approval.

Below is a list of pertinent chapters from the API MPMS that are excellent references for metering and measurement station design and performance. These chapters and the sections within provide detailed recommendations on provers, meters, metering stations, sampling and calculations of gross and net volumes. This is by no means an exhaustive list as the MPMS contains twenty two chapters, though is a great beginning for measurement fundamentals.

Manual of Petroleum Measurement Standards (MPMS)

Ch. 4 Proving Systems

Ch. 5 Metering

Ch. 6 Metering Assemblies

Ch. 7 Temperature Determination

Ch. 8 Sampling

Ch. 12 Calculation of Petroleum Quantities

Ch. 14 Natural Gas Fluids Measurement

Ch. 18 Custody Transfer

Ch. 21 Flow Measurement Using Electronic Metering Systems

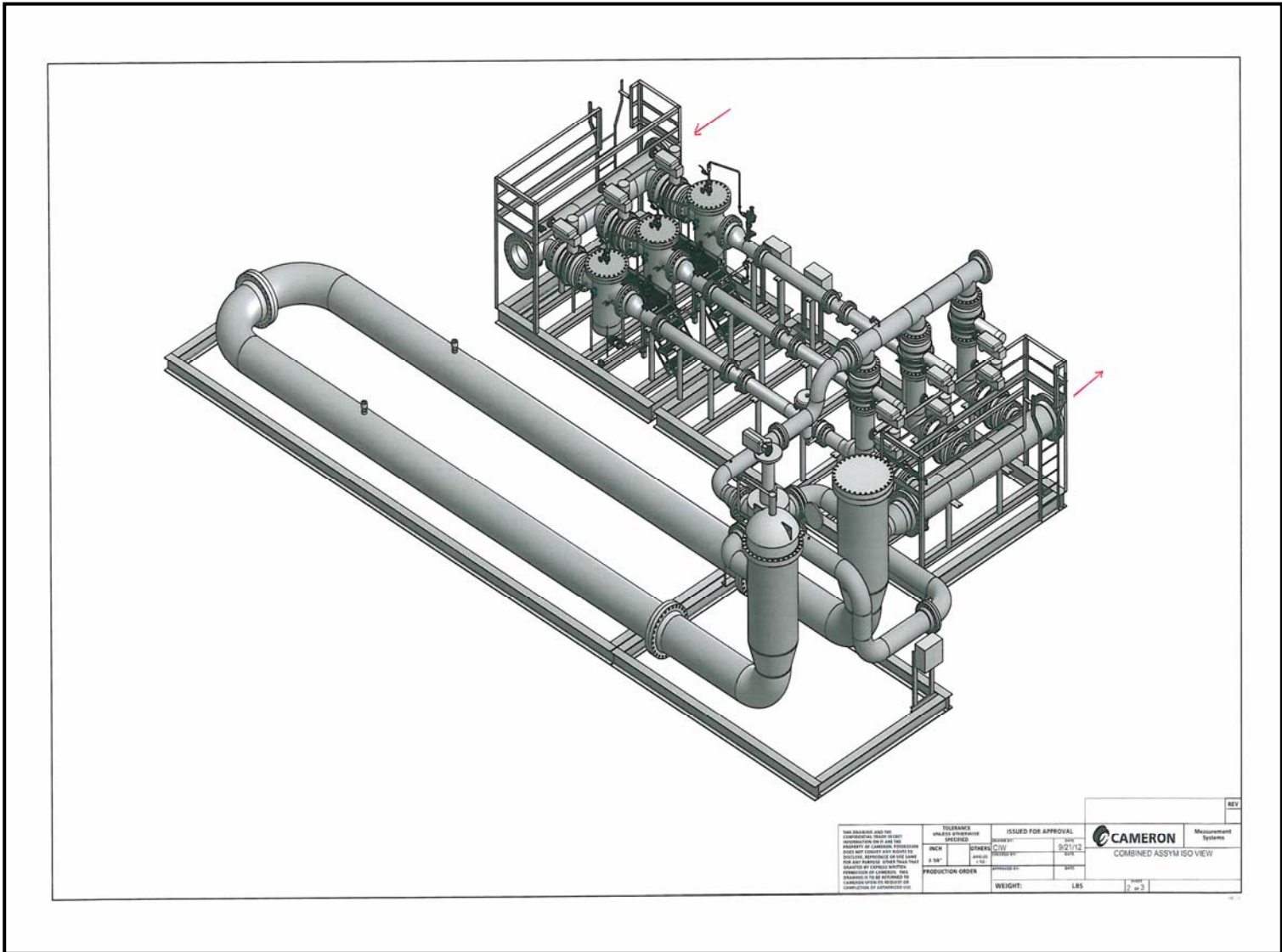

Figure 1 – Triple Run Liquid Metering System with Bidirectional Prover Components and Assembly

Figure 1 above and Figure 2 below are triple turbine meter run measurement stations. The illustration above also contains a bidirectional prover. These figures can be referenced throughout the remainder of this paper as the various components and their functions are identified and described.



Figure 2 – Triple Turbine Meter Measurement Station

Figure 3 below is a comprehensive list of parameters and customer information that is helpful when designing a measurement system.

Figure 3 – Engineered Measurement Station Checklist

ENGINEERED MEASUREMENT STATION CHECKLIST				
<u>Process Conditions</u>				
Flowing Media to be measured: (Crude, LPG, Other-Please Specify):				
SG or Density:	Viscosity:			
Flow Rate:	Minimum	Maximum	Normal	
Operating Temperature:	Minimum	Maximum	Normal	
Operating Pressure:	Minimum	Maximum	Normal	
ANSI Rating:	150	300	600	900 1500
Flange Face:	RF	RTJ		
Inlet/Outlet Manifold Piping Size:				
Valve Operators:	Manual	Electric	Hydraulic	Pneumatic
Electrical: Class	Group(s):	Division		
Power Available:	Voltage	Phase		
Site Location:	Onshore:	Offshore:		
<u>Inspection/Coating</u>				
X-Ray:	100% per API 1104:			
Hydrostatic:	Duration:			
Paint Specifications:				
<u>General</u>				
Strainer Size:	Special Mesh Size:	DP Gauge:	DP Transmitter:	
PD Meter:	Turbine:	Coriolis:	Ultrasonic:	
Preferred Meter Size:	Number of Meter Runs:			
Local Indication on Meters or Flow Computer Output:				
Drain/Vent Piping Required:	Drip Pans:		Grating:	
<u>Meter Prover</u>				
Portable Prover:	Bi-Directional Prover:	Small Volume Prover:		
<u>Samplers - Densitometers</u>				
Air or Electric Sampler:				
Size of Sample Container:				
Brand of Sampler Required:				
Densitometer Required:				
Static Mixer:				
Density Range:	Insertion or Line Mount:			
<u>Flow Computer/Instrument Panel</u>				
On Meter Skid:		Remote Mount Panel:		
Single Flow Computer for Each Run or Multi-Run Flow Computer:				
Flow Computer Required:				
Desktop HMI:		Panel Mount:		
PLC (if required):	Allen-Bradley:	GE Fanuc:		

Inlet Block Valves

Block valves at the inlet to each meter section or meter run provide for isolation of the meter run for maintenance purposes without interrupting flow of the entire station. A spare meter run is sometimes provided in the station to maintain full station flow rate capacity while allowing maintenance of one line. The inlet valve is usually a full bore gate valve, especially for crude oil applications, though full bore ball valves and occasionally triple offset butterfly valves can also be used in clean product applications. The inlet valve is normally open and usually does not require automation though in larger sizes actuation is recommended.

Strainers

The purpose of the strainer at the inlet to each meter run is to filter out debris carried by the liquid which could damage the meter or otherwise compromise the performance of the metering station. A differential pressure instrument or gauge on the strainer is used to indicate the pressure drop across the strainer. When the pressure drop increases due to debris accumulation in the strainer basket, this can indicate to the operator to clean the screen or basket. The strainer body, which is a high point in the piping system upstream of the meter, provides a good location for an air eliminator to vent air or gas vapors during startup and normal operation. Any air or gas in the liquid stream will affect the volume measured by the meter and if severe can lead to damage for a turbine and PD meters. The strainer allows for air in the flow stream to separate from the liquid due to reduction in fluid velocity as the liquid passes through the strainer. It is important that the strainer mesh or basket be properly sized for the process parameters of the product. Fluid properties such as density, viscosity and flow rate are considerations in strainer design in addition to amount of allowable pressure drop during normal operating conditions.

Meters and Flow Conditioning

The primary measurement device is the meter and is the most critical component of the measurement system. For optimum performance the meter must be capable of covering a wide flow range over which the meter maintains a linear pulse output with respect to flow rate; typically, $\pm 0.25\%$ for a 10:1 flow range. For custody transfer and fiscal measurement, the meter could be a turbine meter, a positive displacement meter, an ultrasonic meter or a Coriolis meter. A turbine meter and ultrasonic meter offer the advantages of availability in higher flow capacities and savings in weight, space and maintenance. Both the turbine meter and the ultrasonic meter require design and installation of straight sections of pipe upstream and downstream of the meter to condition the flow profile of the liquid stream. In addition to straight sections of pipe, flow conditioning elements may be required with some meters and is normally part of the upstream meter tube. Flow conditioners come in various types, though the most common for liquid applications is the engineered flow conditioning plate with a specific number of holes and hole sizes across the plate. Positive displacement meters and Coriolis meters do not require upstream or downstream straight piping. The API Manual of Petroleum Measurement Standards Chapter 5 provides the guidelines for each of these flow meter installations and discusses flow profiles in detail.

Flow Control Valves

Flow control valves are used in multiple meter run installations to equalize flow in all meter runs where an imbalance might otherwise exist. Maximum throughput is thereby realized by operating each meter near its maximum capacity. Flow control valves are also used during meter proving to maintain the flow at the same rate at which the meter normally flows. In addition, flow control valves provide the means to operate each meter at various flow rates over its characteristic curve.

These valves are also used to provide back-pressure control to prevent vaporization or gas-breakout of the metered product. This is important when metering crude oils with high vapor pressures as well as for NGLs and LPGs. Vaporization occurs when the pressure drop across the strainer or meter exceeds the product's vapor pressure. This results in poor measurement and ultimately is a poor system design.

The flow control valve location shown in the diagram provides optimum control for all metering applications, while avoiding problems associated with location of a flow control valve between the meter and the prover. The indicated arrangement will result in better flow control and minimize the difference in fluid conditions between the meter and the prover. Optimum proving results are obtained when the meter prover operates as close as possible to the metering conditions.

Flow control valves should be designed to fully operate, open and close, while under the maximum system upstream pressure and at the same time with no pressure downstream. This will ensure avoiding damage to the valve when the valve operates against full differential pressure. Careful evaluation should be given to the desired action of the flow control valve upon loss of either its control signal or actuator power. The valve may be designed to open, close or remain in its current position when signal or actuator power fails.

Prover Inlet and Meter Run Outlet Block Valves

These valves are normally plug valves with high integrity sealing capabilities. These valves block and seal the upstream flow from passing through as well as block and seal the downstream product from passing through the valve. The valves also provide the capability to verify the seal integrity with a bleed valve in the body cavity. Hence, the double block and bleed designation. These valves are normally motor operated valves.

The meter run outlet block valve is located at the outlet of each meter run (downstream of the flow control valve) and is used to allow or open the flow through the meter run and to block or close off flow when so desired. When a meter run is designated as the spare, this downstream valve is closed preventing fluid from the outlet header to reverse flow through this unused meter.

The prover inlet valve connects each meter run (upstream of the flow control valve) to the prover inlet manifold. It is used to divert flow from the selected meter run to the prover. Flow is routed to the prover by opening the prover inlet block valve, followed by closing the downstream meter block valve of that meter run. This action diverts all flow for that meter run to the prover. The valves will stay in this position until proving that meter is complete. At completion of the successful prove, the outlet block valve will be opened and the prover inlet valve closed, resuming normal meter station operations.

Again, to ensure accuracy of metering and proving, the downstream and prover block valves must be of a high reliability, double block and bleed design. Due to the high frequency of operation of these valves in multiple meter systems, the ability of the valves to maintain bubble tight shut-off over the long term is extremely important, as a small leakage will cause measurement errors and difficulty in maintaining meter repeatability during proving. These valves should be supplied with a means to verify seal integrity.

Prover

The mechanical displacement meter prover provides the means for calibration of each meter to a known volumetric standard. This is accomplished by displacing a volume of liquid between two points (switches) by a mechanical displacer inside the prover pipe while the meter signal is being recorded. The volume between switches is pre-calibrated by the water draw method using calibrated test measures certified and traceable to the National Institute of Standards (NIST). An in-situ prover allows continuous flow through the meter being calibrated, with the liquid at its actual flowing conditions, without the need to start or stop the flow. It is desirable to have a permanently installed prover to allow for frequent calibration of the meters in order to maintain long-term accuracy. A bi-directional prover is illustrated in Figure 1; however bi-directional, uni-directional and compact or small volume prover types are also used in measurement systems.

Four-way Valve

The four-way valve diverts the flow in either direction through a bi-directional prover loop. For a uni-directional prover, a sphere interchange and seal assembly is used instead of a four-way valve due to the different principal of operation of the prover. In either case, reliable performance is necessary, and a device for checking the valve or interchange seal integrity is recommended. Typically a differential pressure indicator is provided for this purpose.

Detector Switches

The sphere inside the prover pipe or the piston in a compact prover actuates detector switches mounted in or on the prover. The switches start and stop a digital counter in the flow computer connected to the meter that is being proved. The resulting meter pulse count, temperature and pressure correction factors and prover base volume data are used to determine the meter factor for each meter.

Instrumentation

Pressure and temperature transmitters are located downstream of each meter and on the prover. The transmitters on the meter runs are connected to the flow computer and are used to input actual flowing conditions of the fluid during metering. This is for gross volume calculations. The flow computer retains this data in historical files then calculates net volume using base conditions. These are the corrections for volume of the liquid due to pressure and temperature effects.

The transmitters on the prover are used to ensure flowing temperature and pressure are comparable and within tolerance of the metered temperature and pressure readings in order to initiate the proving functions.

A densitometer is provided in the system for a live flowing density input to the flow computer. It is often part of the quality measurement system in a fast loop sampling arrangement.

The densitometer is also used when inferred mass measurement is required. This is used in conjunction with a volumetric meter, such as turbine, ultrasonic or PD when metering NGLs or LPGs. In this case, a means to calibrate the densitometer in the field is required and this is done using a pycnometer in an insulated calibration loop.

Control Panel

Depending upon the extent of remote operation desired, system operations information is transmitted to and controlled from an automated instrumentation or control panel located remotely from the meter station. The software system is designed to automate the system control functions, provide data logging and perform calculations for liquid measurement. Typically, the flow measurement parameters of each metered stream are logged by the flow computer, which calculates liquid volume corrected to standard temperature and pressure conditions. In a multiple meter run system, the same signals may be connected to the system supervisory system, which provides total station flow data, controls valve positions, and indicates status and alarms.

The control panel for a measurement system consists of an enclosure with panel mounted flow computers, a rack mounted PLC, power supplies, and terminal strips for field wiring termination. The operator interface is a supervisory computer system and consists of an HMI with a desktop computer and/or a panel mounted display screen. The supervisory system will include detailed graphics of the metering system on the display with dynamic real-time operational information data such as flow rates, temperatures, pressures, and valve positions. The control panel is programmed to automatically initiate meter provings, provide scheduled reports and exception reports, and alarm on out of tolerance conditions.

Sampling System

While meters are used to ensure product quantity or volume, so is a properly designed sampling system used to ensure product quality. The sampling system may include a number of instruments such as a densitometer, BS&W monitor, pressure and temperature transmitters, sample containers, controllers and other instrumentation as required. A detailed mixing analysis is required to properly design the sampling system for a given application. Of utmost importance is to extract the best possible representative sample from the flow stream, and proper mixing is critical to obtain it. Sampling systems can be as simple as an in-line static mixer with a sample extraction probe to redundant jet mixing designs with heated enclosures and automatic container selection. See figure 4 below for an illustration of a jet mix system.



Figure 4 – Jet Mix Sampling System

Mechanical Design

Arrangement of piping and equipment in a metering system should allow suitable access for operation and maintenance of equipment, while minimizing space requirements. Piping manifold and header design is important to the liquid flow pattern in the station. Proper sizing and arrangement will provide better balance of flow between meter tubes without sacrifice due to excessive pressure drop. Manifold or header liquid velocity should not exceed 15 feet/second for best flow distribution and lower pressure drop. Valve sizing is also important in regard to pressure drop. Block valve sizes are usually one pipe size larger than the meter for turbine meter applications, and the same size as the meter for positive displacement meter applications.

Features that are included in the station to improve operation and maintenance include quick opening closures on strainers and prover launch chambers, and jackscrews and spacer plates in the meter section to facilitate removal of meters. A jib, monorail or bridge crane is often included to aid in strainer basket removal, valve maintenance or sphere installation and removal. In liquid systems, a pressure relief valve should always be included in each section of pipe that might be blocked off while filled with liquid. The relief valve will protect piping and equipment from being over pressured by liquid expansion due to solar heating.

Modular design of a liquid measurement system offers a significant economic advantage over a field-constructed system. Structural steel skid frames may be used to support the pre-fabricated piping and instrumentation system. Electrical wiring of all devices to terminal strips in local mounted junction boxes minimizes site installation time. System functionality, complete with remote instrumentation and software, may be verified in a controlled environment rather than in the field.

The units are then easily transported to the field, where tie-in of piping connections and wiring between the remote panel and the local junction boxes is completed. Installation of a pre-checked unit ensures that all components are compatible and that the system is in optimum working condition prior to filling it with product and commissioning the measurement system at the site.

CONCLUSION

Design of liquid measurement stations must include careful evaluation and selection of all components that affect the transfer units of measurement, either volumetric or mass. By minimizing the measurement uncertainty for each parameter that affects liquid measurement, such as operating temperature or pressure, the overall system uncertainty is reduced. In addition, proper operation of the metering, proving and sampling systems, combined with periodic maintenance and calibration of devices that affect flow measurement will result in optimum performance of the system.