

FUNDAMENTALS OF PRESSURE & TEMPERATURE MEASUREMENT

Brian Cleary

Emerson Process Management

Why Measure Pressure & Temperature?

Measurements of pressure and temperature are made for many reasons and by several methods. This paper will focus on measurements made during gas production and transportation. In this industry, pressure and temperature measurements are primarily being made for three (3) reasons:

- Safety
- Control
- Compensation

The properties of gas follow the Ideal Gas Law:

The diagram shows the Ideal Gas Law equation $PV=nRT$ in large orange letters. Five blue arrows point to the variables: 'Pressure' points to 'P', 'Temperature' points to 'T', 'Number of moles' points to 'n', 'Volume' points to 'V', and 'Gas constant' points to 'R'.

So with everything else being constant, when pressure of a gas increases, so does its temperature, when temperature goes up, so does its pressure.

In safety applications, it is important to measure pressure and temperature to understand, notify, and mitigate the possibility of dangerous situations occurring due to the physical changes of the gas, or associated equipment such as pumps and compressors. Pipelines and storage vessels are designed to contain gas only under specified conditions, when these conditions are exceeded, catastrophic events can occur. Also, motor bearings and pump seals failures also can be identified by changes in temperature and pressure, and machinery loss prevented.

In control applications, pressure and temperature measurements are made, along with other process variables, to regulate the conditions and optimize the process around a certain set of criteria.

In compensation applications, pressure and temperature measurements are made to calculate the mass/volume relationship during gas transfer and storage by correcting for density changes due to pressure and temperature variability.

Units of Measurement

Pressure and temperature can be measured in many different scaling units. But the most important thing to understand is that all parties involved must agree on a common set of units, or a common set of conversion factors, so everyone has the same understanding of the process conditions.

Common Pressure Units

- PSIA
- PSIG
- Inches H₂O
- mmHg
- Pascals
- Torr

Common Temperature Units

1. Degree F
2. Degree C
3. Degree K
4. Degree R

In the United States, the most common unit for pressure measurement is “PSI”, meaning “pounds per square inch”.

However, it is most important to understand the base reference condition of where the measurement starts from: PSI“A” means the base pressure is 0 absolute (full vacuum) which is approximately -14.7 psi from 0 PSI“G”, where the base condition is 0 atmospheric pressure (at sea level). Inches H₂O is a common unit of pressure for measuring the differential pressure/flow of a fluid as it moves through a restriction (i.e.: orifice plate) in a pipe, or in the measurement of the head pressure/level of a fluid in a column or other vessel.

The most typical unit of measurement for temperature in the United States is made using the Fahrenheit scale, in degrees F. As everyone knows, in the Fahrenheit scale, water freezes at 32 and boils at 212 degrees (at sea level). In the other common scale, Celcius (or Centigrade), using degrees C, water freezes at 0 and boils at 100. The conversion between these two most widely used scales can be made as follows:

$$\begin{aligned} \text{°C to °F} & \quad \text{Multiply by 9, then divide by 5, then add 32} \\ \text{°F to °C} & \quad \text{Deduct 32, then multiply by 5, then divide by 9} \end{aligned}$$

The formula is:

$$\text{Celsius to Fahrenheit: } (\text{°C} \times \frac{9}{5}) + 32 = \text{°F}$$

$$\text{Fahrenheit to Celsius: } (\text{°F} - 32) \times \frac{5}{9} = \text{°C}$$

Most custody transfer measurements are made using a defined set of base conditions that compensate volume for density changes. The base conditions are typically: 1 atmosphere of pressure (14.7 PSIA, or 0 PSIG, at sea level) and at 60, 68 or 75 degrees F, or at 20 or 25 degrees C. The exact pressure and temperature base conditions and units used in these critical measurements should be defined in the custody transfer contract.

Methods of Measurement

Pressure Measurement

The most common methods of measuring pressure in industrial applications are through the installation of pressure gauges and pressure transmitters. Pressure gauges are usually non-powered and typically consist of a bourdon tube connected to a lever that is then connected to a pointer on a dial. The shape of the bourdon tube changes with pressure and the resultant shape causes the pointer to move to indicate current process pressure. The main purpose of a pressure gauge is to provide a local readout of the pressure. For applications that require a remote readout, and/or higher accuracy (for safety, process control and process compensation) a powered pressure transmitter is used.



Figure 1 – Pressure Gauge

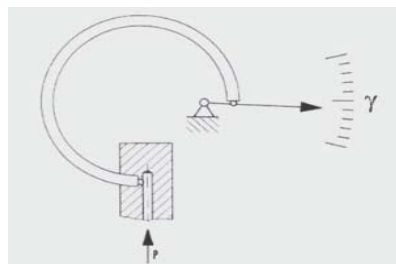

Figure 2 – Pressure Gauge Design

Pressure transmitters consist of a powered sensor that detects the pressure, and an electronics housing that includes the electronics, that provide power to the sensor, as well as an output circuit that sends the pressure variable value to a remote host device. The electronics housing also includes the terminals to connect the power and output wires, as well as a local display, if needed. Various electronics housings are available to meet the specific hazardous area classification the transmitter is to be installed in.

There are three primary pressure sensor technologies currently being used by the major pressure transmitter manufacturers:

Capacitance

Strain gauge

Resonance Crystal

In a capacitance sensor, there is a common plate, and 2 opposing plates, one on the high pressure side, and the other on the low or reference pressure side. These plates are encapsulated in oil and hydraulically connected to sensing diaphragms that are

exposed to the process pressure(s). As the pressure on the high pressure diaphragm increases, the resulting fluid movement forces the high side plate to move closer to the common plate, thereby decreasing the capacitance between them, this fluid movement also causes the low side plate to move away from the common, thereby increasing the capacitance between them. A circuit is used to measure the differential capacitance and directly correlate the capacitance values to process pressure.

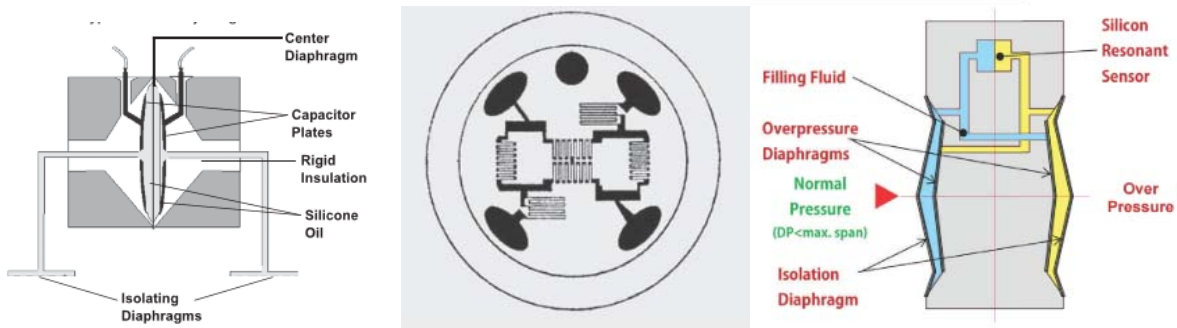

Figure 3 – Capacitance Pressure Sensor Figure 4 – Strain Gauge Sensor Figure 5 – Resonance Pressure Sensor

In a strain gauge based pressure transmitter, there is typically a circuit grid deposited on a substrate. The substrate bends as it is exposed to pressure and the deformation of the grid causes a resistance change in the circuit that is proportional to the pressure change. The resistance value is fed into a Wheatstone bridge circuit to linearize, then amplified and placed in the transmitter output circuit.

A resonance crystal based pressure transmitter is similar to the stain gauge, except that the frequency of a crystal changes directly in proportion to the amount of pressure it is exposed to.

Temperature Measurement

The four technologies most widely used to measure temperature in our industry are as follows:

- Resistance Temperature Detectors (RTD)
- Thermocouples
- Thermometers (Fluid filled and Bi-Metallic)
- Infrared Technology

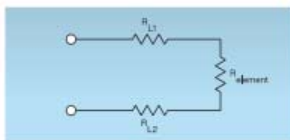

$$R_{\text{measured}} = R_{L1} + R_{\text{element}} + R_{L2}$$

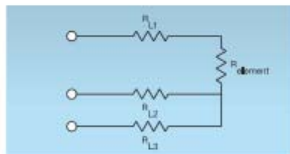

$$R_{\text{measured}} = R_{L1} + R_{\text{element}} + R_{L2} - (R_{L2} + R_{L3})$$

$$= R_{L1} + R_{\text{element}} = R_{L3}$$

$$= R_{\text{element}} \quad (\text{if } R_{L1} = R_{L3})$$

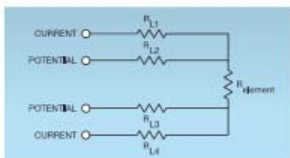

$$R_{\text{measured}} = R_{\text{element}}$$

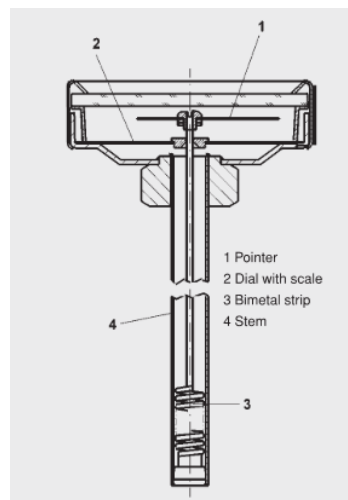
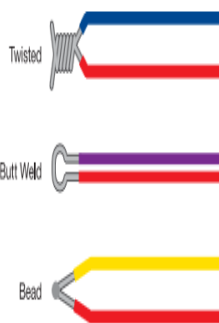

Figure 6 – RTD Figure 7 – Thermocouple Figure 8-Bimetallic Thermometer Figure 9 – Infrared Detector

RTDs and thermocouples are most widely installed, usually mounted in protection tubes called thermowells, and inserted directly into the process. The output from these sensors is considered to be low level and must be installed with an amplification circuit located either in the host device, or in a (temperature) transmitter which then sends the amplified signal to a host device. Thermometers can also be installed in thermowells, but provide local readout only. Infrared sensing technology is considered “non-contact” and can be used either as a single point device for continuous or periodic measurement, or as part of a thermal imaging system.



Figure 10 – High Temperature Ceramic Protection Tube

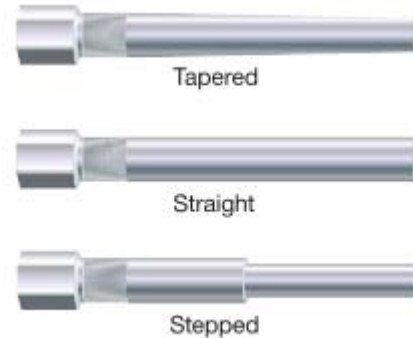

Figure 11 – Thermowell Stem Styles

Installation Considerations

There are many criteria that can be used to select the best method to measure pressure and temperature:

- Will the measurement devices be wired or wireless?
- Does the situation require continuous or periodic measurement?
- Will the measurement be made for local or remote monitoring?
- Is it for a new installation, or retrofit of an existing one?
- What are the performance requirements (safety, control or compensation)?
- What will be the total installed cost/budget for the measurement.

The time, effort and cost to wire devices has led to rapid adoption of wireless measurement technology in our industry. However; wireless measurement is not recommended for applications that require continuous process variable updating, such as for safety or high speed control situations.



Figure 12. Examples of Wireless Instruments Used to Measure Temperature and Pressure

Gauges can be considered for applications that require only periodic and local monitoring.

In new installations, a cost – benefit analysis can be made which should result in selecting the device that provides the user with the “best value” for the application. In situations where a retrofit of an existing device must be made, one should evaluate whether the replacement device should have the same fit/form/function as the old device, or can justify the cost to install a newer technology device to receive the added benefits it may provide.

Many manufacturers offer instruments that can be classified as “fit for purpose” and identified as:

- General Purpose
- “Classic” Performance
- High Performance

General Purpose would provide the lowest tier of performance, at the lowest price. “Classic” Performance can be considered to be in line with the industry standard of performance. Instruments identified as having “High” Performance indicate that their features and performance specifications significantly exceed those with “classic” performance and are usually offered at a price that justifies their improved performance and/or additional features

Performance requirements of the pressure and temperature measurement are determined by the application. Installations for safety requirements need the most reliable and responsive measurements possible so that any unsafe condition can be identified quickly to provide the most time for mitigation. Measurements for process control are much more application dependent, speedy processes require very responsive measurements, processes involving the production and distribution of very valuable products require the highest accuracy measurements possible. A general requirement for all process control applications is that the measurements are repeatable under the same process conditions.

Performance Comparisons

Pressure Measurement

Pressure Gauges are used for read-only measurements and are valued for their reliability and repeatability, accuracy varies, but generally falls in the +/- 1 to 5% range.

Pressure Transmitters are used in all applications that involve safety (perhaps also used in conjunction with a pressure switch), and process compensation and control. All transmitter performance is listed in two (2) ways:

Reference Accuracy

Total Probable Error

Reference accuracy can be considered to be the performance of the transmitter “out of the box” and in a controlled environment. It is the expected/allowable process variable measurement error (combined errors due to sensor linearity, hysteresis and repeatability), under a specified set of referenced conditions. Reference accuracy can be used to compare the three performance classes as follows:

General Purpose Pressure Transmitters: +/-0.2% of range error

Classic Performance Pressure Transmitters: +/-0.075% of span error

High Performance Pressure Transmitters: +/-0.0125% of span error

Total Probable Error is the calculated error of the measurement device under a set of “real world” conditions and provide a better expectation of the measurement error when the device is in operation. Total probable error combines the reference accuracy error with any other errors due to ambient and process changes. These error values are combined using the Root-Sum-Square (RSS) method of statistical analysis to generate the Total Probable Error that can be expected by the measurement device. The typical TPE for the three performance classes are as follows:

General Purpose Pressure Transmitters: +/-1 to 3%

Classic Performance Pressure Transmitters: +/- 0.5 to 1%

High Performance Pressure Transmitters: +/- 0.1 to 0.4%

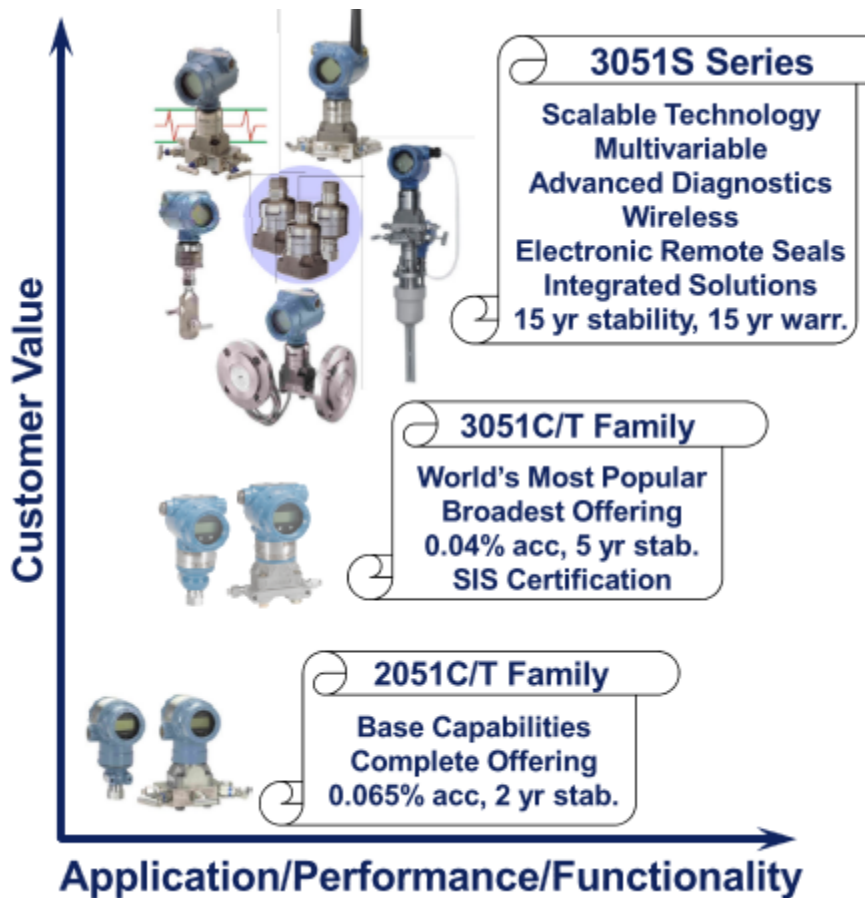

Figure 13 – Transmitter Performance Classes

Temperature Measurement

The performance of thermometers is very dependent on their size for measurement resolution. Overall accuracy in the range of +/-1% is attainable.

There are two types of temperature sensors most widely used in our industry:

Resistance Temperature Detectors (RTD)

Thermocouples

RTDs are based on material resistance change due to temperature. There are many types of RTDs available based on the actual sensor material. The material most widely used is Platinum. Platinum is used because its resistance change due to temperature change is very linear, thereby not requiring much external linearity compensation to make an accurate and repeatable measurement. RTDs are identified by their output characteristics. The most popular RTD is the 100 Ohm Platinum, with alpha of 0.00385. The alpha value is based on the purity of Platinum being used and is the value of its coefficient of resistance, or output curve (ohms/ohms per degree C). The 100 Ohm designation means that the sensor will have 100 ohms of resistance at 0 degrees C. So at 0 deg. C (32 degrees F, the resistance of a 100 PT, alpha 385 (shortened), is 100 ohms, at 100 deg. C (212 deg. F) the resistance is 138.5 ohms.

There are two (2) performance classes of RTDs, Class A and Class B, which has to do with their interchangeable accuracy, and two (2) types of sensor manufacture, wire-wound and thin film. Generally, wire wound sensors use more Platinum, so are more expensive, but have a higher temperature range and can be made more accurate. Thin film sensors are cheaper to produce, have a faster response to temperature change and can handle vibration better.

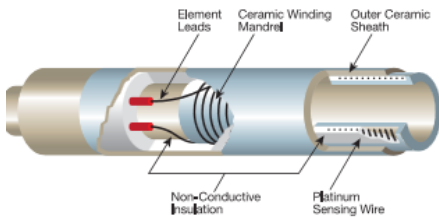

Figure 14 – Wire Wound RTD

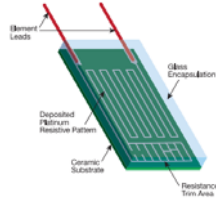

Figure 15 – Thin Film RTD



Figure 16 – Sensor Assembly

The RTD resistance change due to temperature change is not perfectly linear, and no matter if you use a Class A or Class B Performance Class sensor, there will still be error in temperature measurement. The most common way to eliminate most of these errors is to have the RTD sensor manufacturer include the Callendar-Van Dusen (CVD) values for each RTD provided. Entering the CVD values into the device the RTD is connected to will compensate for the sensor specific errors.

A thermocouple (T/C) is a closed-circuit thermoelectric temperature sensing device consisting of two wires of dissimilar metals joined at both ends. A current is created when the temperature at one end or junction differs from the temperature at the other end. This phenomenon is known as the Seebeck effect, which is the basis for thermocouple temperature measurements.

One end is referred to as the hot junction whereas the other end is referred to as the cold junction. The hot junction measuring element is placed inside a sensor sheath and exposed to the process. The cold junction, or the reference junction, is the termination point outside of the process where the temperature is known and where the voltage is being measured. (e.g. in a transmitter, control system input card or other signal conditioner.) According to the Seebeck effect, a voltage measured at the cold junction is proportional to the difference in temperature between the hot junction and the cold junction. This voltage may be referred to as the Seebeck voltage, thermoelectric voltage, or thermoelectric EMF. As the temperature rises at the hot junction, the observed voltage at the cold junction also increases non-linearly with the rising temperature. The linearity of the temperature-voltage relationship depends on the combination of metals used to make the T/C.

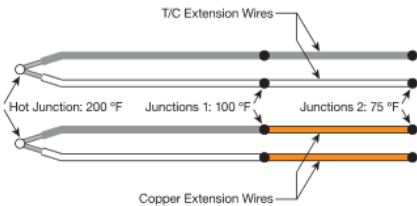

Figure 17 – Thermocouple Sensor

The voltage measured at the cold junction correlates to the temperature difference between the hot and cold junctions; therefore, the temperature at the cold junction must be known for the hot junction temperature to be calculated. This process is known as “cold junction compensation” (CJC). CJC is performed by the temperature transmitter, T/C input cards for a control system, alarm trips, or other signal conditioner. Ideally the CJC measurement is performed close to the measurement point as possible because long T/C wires are susceptible to electrical noise and signal degradation. Performing an accurate CJC is crucial to the accuracy of the temperature measurement. The accuracy of the CJC is dependent on two things; the accuracy of the reference temperature measurement and the proximity of the reference measurement to the cold junction. Many transmitters use an isothermal terminal block (often made of copper) with an imbedded precision thermistor, an RTD or an integrated circuit transistor to measure the temperature of the block.

Thermocouples are designated by the material of two dissimilar metal wires

ANSI Letter Design	Leg	Metallic Composition	Melting Point		Potential Temperature Range
			°C	°F	
B	P	Platinum – 30% Rhodium	1825	3320	0 to 1820 °C 32 to 3308 °F
	N	Platinum – 6% Rhodium			
E	P	Chromel®	1220	2230	-270 to 1000 °C -454 to 1832 °F
	N	Constantan			
J	P	Iron	1220	2230	-200 to 1200 °C -328 to 2192 °F
	N	Constantan			
K	P	Chromel®	1400	2550	-270 to 1372 °C -454 to 2501 °F
	N	Alumel®			
N	P	Nicrosil	1340	2440	-270 to 1300 °C -454 to 2372 °F
	N	Nisil			
R	P	Platinum – 13% Rhodium	1770	3215	-50 to 1768 °C -58 to 3214 °F
	N	Pure Platinum			
S	P	Platinum – 10% Rhodium	1770	3215	-50 to 1768 °C -58 to 3214 °F
	N	Pure Platinum			
T	P	Copper	1080	1980	-270 to 400 °C -454 to 752 °F
	N	Constantan			

Thermocouples can be identified by the color of the wires, in North America the leadwire color standard is:

Thermocouple Type	Leadwire Colors
B	Red/Grey
E	Red/Purple
J	Red/White
K	Red/Yellow
N	Red/Orange
R	Red/Black
S	Red/Black
T	Red/Blue

Just as there are performance classifications for RTD (Class A and Class B), thermocouple performance is identified by “Tolerance Class”. There are three thermocouple performance classes: Tolerance Class 1, Tolerance Class 2 and Tolerance Class 3. The specific values of allowable manufacturing tolerance for each class vary depending on the thermocouple type.

The following is a table comparing the attributes of RTDs verses Thermocouples:

Attribute	RTD	Thermocouple
Accuracy Interchangeability	Class A: $\pm [0.15 + 0.002 (t)]$ Class B: $\pm [0.30 + 0.005 (t)]$ Per IEC 60751	Typical is ± 1.1 °C or $\pm 0.4\%$ of measured temperature (Greater). Depends on Type and Range. Degraded by extension wire.
Stability	± 0.05 °C per 1000 Hrs at ≤ 300 °C. Greater at higher temperatures. Wire wound better than thin film.	Highly dependent on T/C type, quality of the wire and operating temperature. Typical is ± 2 to 10 °C per 1000 Hrs.
Speed of Response in Thermowell Installation in Liquid	For 6mm sensor about the same as T/C.	For 6mm sensor about the same as RTD. Slightly faster for 3mm sensor.
Calibration	Easily recalibrated for long service life. Best accuracy with Sensor-Transmitter Matching.	Limited to in situ comparison to "Standard T/C".
Potential Temperature Range	-200 to 850 °C	-270 to 2300 °C
Life Span	Many years. Shorter at higher temperatures.	Degradation indicates frequent replacement. Much shorter at high temperatures. Higher life cycle costs.
Installation Considerations	Use standard copper wire. Good EMI and RFI immunity.	Requires expensive matching extension wire. Low level signal is very susceptible to EMI and RFI.
Vibration Tolerance	Thin film design is very good.	Larger wire diameters are very good.
Life Cycle Cost	Lower.	Higher.
Purchase Cost	Thin film design about the same. Wire wound higher.	Types R and S most expensive.
System Performance with Transmitter	Always better below 650 °C.	Order of magnitude lower.

Temperature sensors are rarely inserted directly into an industrial process. They are installed into a thermowell to isolate them from the potentially damaging process conditions of flow-induced stresses, high pressure, and corrosive chemical effects. Thermowells are closed-end metal tubes that are installed into the process vessel or piping and become a pressure-tight integral part of the process vessel or pipe. They permit the sensor to be quickly and easily removed from the process for calibration or replacement without requiring a process shutdown and possible drainage of the pipe or vessel.

The most common types of thermowells are threaded, socket weld, and flanged. Thermowells are classified according to their connection to a process. For example, a threaded thermowell is screwed into the process; a socket weld thermowell is welded into a weldolet and a weld-in thermowell is welded directly into the process pipe or vessel. A flanged thermowell has a flange collar which is attached to a mating flange on the process vessel or pipe.

Temperature Transmitters are the final piece of a typical temperature sensing assembly. Temperature transmitters are offered in performance classes similar to pressure transmitters. Temperature transmitters are offered in two (2) mounting styles: head mount and remote. In head mount, the transmitter is connected to the sensor and directly mounted on the thermowell. In remote mount installations, the sensor and thermowell assembly is mounted to the process and connected to a remote mounted transmitter via wire. If the sensor is a thermocouple, then thermocouple specific leadwire must be used, if it is a RTD, shielded copper wire is recommended.



Figure 18 – Temperature Transmitters

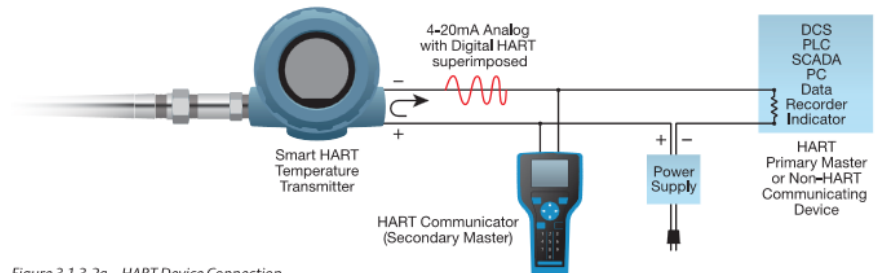

Figure 3.1.3.2a – HART Device Connection

Figure 19 – Temperature Measurement Circuit

In addition to using contacting type temperature measurement devices, there is a growing use of non-contacting infrared technology to measure temperature. There are various hand held and permanent mount styles available for single point or wide area thermal imaging applications.

There are many reasons and methods to measure pressure and temperature in our industry. Selection of the proper method should be based on the specific application requirements, with consideration of what currently is being used, available new technology and the total installed cost verses the budget allotted.



CLAMP -ON
SURFACE MOUNTED RTD WITH
WIRELESS TEMPERATURE TRANSMITTER

Figure 20 – Wireless Temperature Measurement