

Grounding Practices for Automation Controls

Understanding the Key Elements and Resolving Common Problems

Donald R. Long

MTL, Incorporated
7227 Kings Arm Drive
Manassas, VA 20112

INTRODUCTION

Grounding is defined as electrical equipment connected directly to mother earth, or to some conducting body that serves in place of the earth, such as the steel frame of a high-rise building on a concrete footing. Proper grounding is an essential component for safely operating electrical systems. Improper grounding methodology has the potential to bring disastrous results. There are many different categories and types of grounding principles. This paper's focus is to demonstrate proper grounding techniques for low voltage Instrument and Control Systems (IACS) that have been proven safe and reliable when employed in gas measurement facilities.

IACS

For the purposes of this paper, IACS will be defined as instrument and control systems that operate at 50 VDC or less. Unfortunately, proper IACS grounding techniques have often been learned the hard way. Entire natural gas stations have been lost due to poor grounding of electrical systems. Some of these unfortunate incidents and the resultant lessons learned will be described in the paper.

TYPES OF NATURAL GAS FACILITIES

Gate Stations and Peak Shaving Plants

Washington Gas (WG), a local distribution company (LDC), delivers and sells natural gas to more than one million metered customers in the metropolitan Washington D.C. area and adjoining areas in Virginia and Maryland. Washington Gas' distribution facilities consist mainly of 34 unmanned transportation gate stations, 500+ distribution regulator stations, and three peak shaving plants.

Gate stations are facilities where Local Distribution Companies (LDCs) purchase natural gas from transcontinental high pressure pipeline companies and condition the gas before transporting it to the end users (see figure 1). Conditioning the gas at gate stations typically consists of filtering, heating, throttling, measuring the quantity and quality of, and odorizing the gas. After passing through a gate station, natural gas will generally be throttled to lower pressures through a series of distribution regulator stations before finally being delivered to the customer.

Most LDCs and transmission pipeline companies utilize peak shaving facilities to help meet customers' needs during periods of high usage demands. Typically, peak shaving facilities have large quantities of fuel stored on site. The fuel is acquired during low consumption periods (e.g., spring, summer, and fall) and stored on-site until peak energy usage days require the fuel to be dispensed into the pipelines.

Examples of peak shaving facilities are:

- High-pressure natural gas plants that store gas in high pressure (generally 2,500 psig or greater) storage bottles or wells,
- LNG plants that store cold liquefied natural gas, and
- Propane/air plants that store propane, then mix the propane with compressed air during production to make a natural gas substitute.

Figure 1 is a picture of WG's Gardiner Road gate station and Figure 2 displays a section of Washington Gas' Rockville high-pressure natural gas and propane/air peak shaving plant.

All these stations and plants use a multitude of SCADA and instrument systems that require adequate grounding of their electrical systems.



Figure 1. Gardiner Road Gate Station



Figure 2. Rockville Peak Shaving Plant

TYPES OF GROUNDS

Any discussion on grounding invariably leads to a discussion on the different types of grounds and the corresponding definition of each. However, it is commonly accepted that grounds in the gas industry can be classified as either dirty or clean. Please refer to Figure 3 for a comparison of the different grounds.

Dirty Grounds

Dirty grounds inside the facility are typically those 120VAC, 220VAC, 480VAC power grounds that are associated with high current level switching such as Motor Control Centers (MCC), lighting, power distribution, and/or grounds corrupted by radio frequencies or electromagnetic interference.

Quite often, the primary AC power coming into the plant can introduce spikes, surges, or “brownouts” that further erode the cleanliness of the AC ground.

Clean Grounds

Examples of clean grounds are the DC grounds, usually 24VDC, that reference the PLC, DCS or metering/control system in the gate station or plant.

Frequently, control systems engineers from the major SCADA vendors recommend isolating these grounds from power grounds. Other clean grounds are those associated with data and communication busses that, due to the vulnerability of low-level CMOS and microprocessor circuits, must be maintained relatively free of noise interference or risk data/communications loss.

Structural Grounds

These are the grounds that physically and electrically tie the facility together and, quite importantly, complete the circuit to the 0V, ground leg of the power distribution transformer. Structural grounds can take many forms.

In a ship, it is the hull of the ship; on an offshore oil/gas platform, it is the structural steel of the platform. In large petrochemical or pharmaceutical plants, a ground grid or mat is installed under the plant or the welded structural steel of the plant itself becomes the 0V electrical power ground.

In the typical gas plant or gate station, the 0V ground reference is most often a heavy gauge copper wire embedded around the base of the building and tied into ground rods at the corners as well as into the AC ground feeds at critical junctures. Not only does this copper ground create the 0V reference for the station’s electrical system, it becomes part of the Faraday cage lightning protection system that will be discussed later.

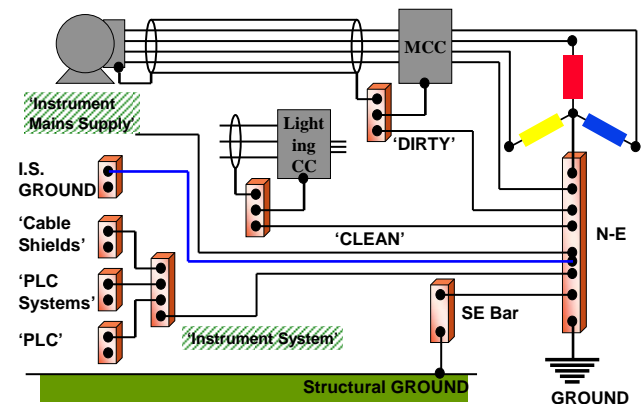

Figure 3. Grounding Types

BUILDING A PROPER GROUNDING BED

There are two basic elements that are used for IACS grounding systems: grounding rods and a grounding grid

Using a grounding rod in a grounding bed system comprises of installing a ground rod (generally by hammering in the rod) into the earth. Grounding rods come in a variety of materials and sizes. The rods typically are made of stainless steel, galvanized steel, copper clad steel, or pure copper all yielding approximately the same lifespan. The rods generally range from ½” to 1” in diameter and from 5 to 10 feet in length. The size of the rod will vary depending on the soil conditions (sandy - high soil resistivity, rocky, silty loam - low soil resistivity, etc.) and the equipment available for installing the rods. It is best to contact a grounding rod manufacturer for help in determining the best rod to use for a given application. Typically, for the soils found in northern Virginia, 5/8” diameter by 8 feet long grounding rods are used. The goal of a grounding rod is to achieve a resistance of 25 ohms or less between the rod’s grounding conductor and the soil in the general vicinity of the rod per NEC 200. The rods are generally installed near the electric utility’s meter, in the vicinity of large above ground structures, and are tied in at various locations to the grounding grid. (see Figure 4).

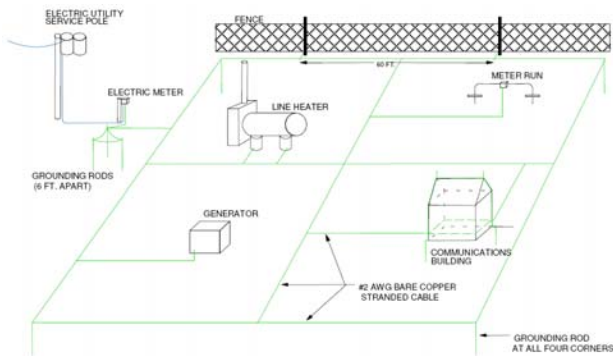

Figure 4. Proper Grounding Bed

The grounding grid portion of a grounding bed consists of burying a bare grounding conductor around the perimeter and across a station or plant, at a depth of 2 to 4 feet below grade. The cable is #2 AWG (minimum) stranded copper cable. This grounding grid is then tied into the electric utility meter earth ground at a location where the grounding grid is closest to the electric meter ground. All electrical equipment and instruments and above ground structures susceptible to lightning strikes are connected to this grounding grid (see Figure 4). Larger above ground structures, such as buildings, will tie into the grounding grid at multiple locations.

It is imperative that in order to construct a premier grounding bed, the grounding grid and grounding rods must be installed deep enough to be in direct contact with conductive earth, not just a wet sandy nonconductive variety of “ground.” In marshy areas it is not unheard of going to a depth of 30 feet to find conductive soil.

CONNECTING IACS TO THE GROUNDING BED

Connecting electrical equipment and IACSs to a grounding bed is called bonding and is done to prevent local potential differences. Local potential differences can be unsafe (causing electric shocks) and can also wreak havoc on IACSs, causing them to function improperly, and fail prematurely. The best method to connect the IACSs to a grounding bed is by using cable clamping connectors and heavy gauge (12 AWG minimum) green vinyl clad or bare stranded copper cable. It is preferable to run this grounding cable along the shortest distance feasible from the instrument or control panel star-point (discussed later) grounding lug to the grounding bed, in order to provide the least resistance possible to mother earth. The resistance along the grounding conductor cable from the IACS to the grounding bed should be 0.1 ohm or less. See Figure 5 displaying a control panel star-point connected to the grounding conductor.

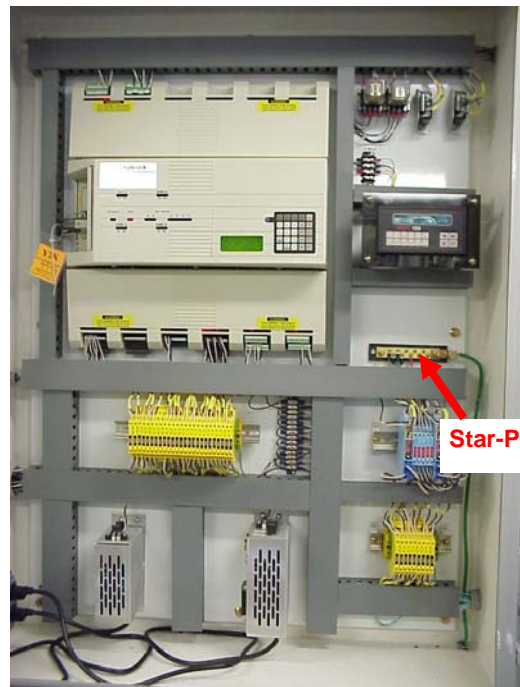

Figure 5. IACS Control Panel Star Point

WHAT IS A FARADAY CAGE?

A Faraday cage acts as a shield against the effects of electromagnetic energy by directing the energy around a structure instead of through it. One can use the grounding grid cable to create a Faraday cage around a station or plant’s above ground structures in order to provide an easy path for lightning strikes to mother earth. The Faraday cage helps protect personnel from injury and sensitive instruments from damage due to electric shock. Figure 6 demonstrates an example of how to design a Faraday cage around a building.

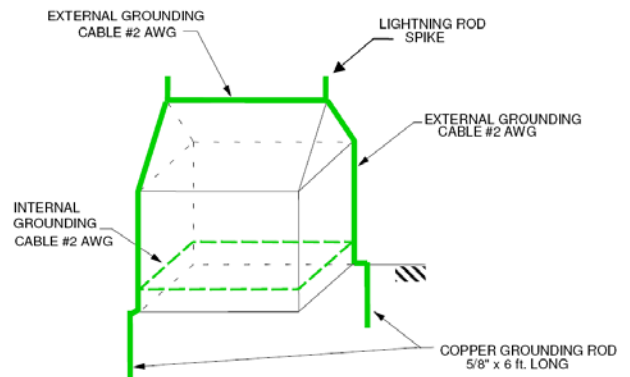

Figure 6. Faraday Cage

STAR POINT GROUNDING, SINGLE POINT CONNECTION

Look at the accompanying AC distribution diagram in Figure 7 and appreciate the fact that all the subsystems in the plant, instrumentation, communication, computers and control, and AC power, are connected to a single point

ground system. This is known as “star point” grounding. Properly done, each subsystem ground is kept as short as reasonably possible and is connected to the star point at only one point. Multiple paths to the ground plane from a subsystem inherently have different resistances. Different resistances to ground produce, by Ohm’s Law, different voltage potentials impressed on the control system.

The net result of not employing star point grounding is increased vulnerability to transient surge damage as well as less reliable control system functioning.

STAR POINT GROUNDING

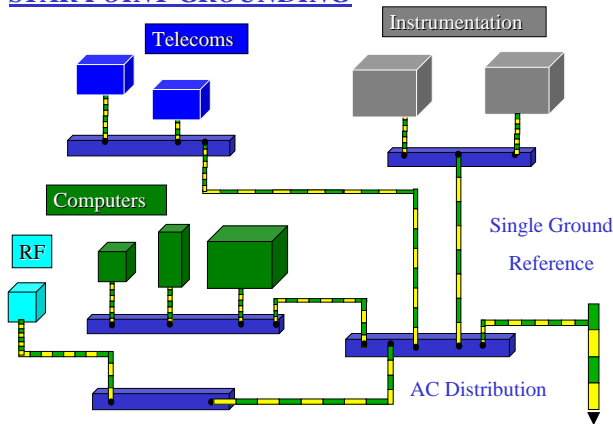

Figure 7. AC Distribution Diagram

For IACS control panel star-point terminal blocks, a marine based 10 or 20 gang-common feed buss bar available at most marine product centers is shown in Figure 8.



Figure 8. IACS Star-Point Termination Bar

HOW NOT TO GROUND!

Do *not* ground various elements of the IACS i.e., shields from field transmitters and the ROC/PLC power supply ground, to different grounds. Figure 9 shows a prime example of how not to ground. In this example, the control loop shields are grounded to a separate ground rod.

Additionally, the control element power supply is grounded to the AC ground but the PLC analog input circuit is left floating. Even in a smaller station, if different instruments are connected to independent ground rods, the reference to ground will vary which will develop localized potential differences. This is a sure recipe for disaster.

HOW NOT TO GROUND

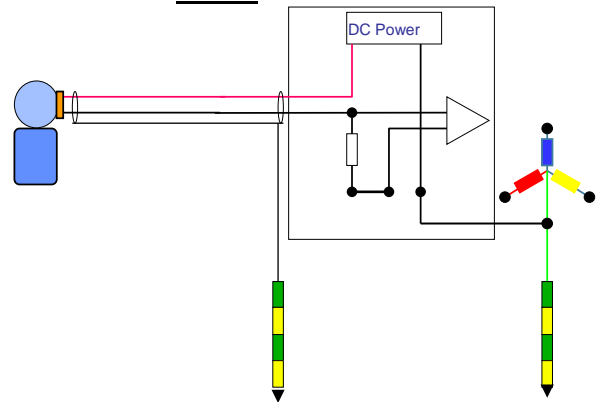

Figure 9. Example Incorrect Ground

The Figure 9 circuit can be remedied by common wiring the field transmitter shields, DC power supply and the PLC to the same 0V, AC ground point, with as short and as heavy gauge wire as practicable. Once this has been achieved, critical reference potentials between the three primary loop elements are equalized.

FIELD TRANSMITTER GROUNDING

Techniques for Grounding Transmitters

The vast majority of transmitter manufacturers recommend local grounding of their products and, in fact, always provide a “ground terminal” on the terminal block to facilitate. The key issue of the 4-20mA transmitter, with or without HART capabilities, the new multivariable transmitters, or even newer Fieldbus transmitters, is the electronics board inside.

This electronics board is increasingly microprocessor and integrated circuit (IC) based, and consequently far more vulnerable to surge currents.

Quite often, this board is offered with integral surge protection, which, at best, is a minimum of protection for the transmitter. If this is the case, then it is mandatory to provide a pathway for the surge current to be diverted from the internal surge device to the ground plane.

When the pipe work that the transmitter is mounted on is not isolated and is part of the terrestrial ground plane, then grounding the transmitter to the pipe is sufficient. If the pipe work is mechanically and electrically isolated then a proven local ground should be connected via a short-as-possible, minimum 12 AWG ground wire.

Caution: When locally grounding a field transmitter with or without internal surge protection, the transmitter electronics becomes vulnerable to lightning/surge currents originating either along the wiring/conduit or traveling from the area of the controller. This is due to the difference in ground potential between the local transmitter ground (0V) and the high ground potential (??V) at the ROC/PLC building caused by a lightning strike as illustrated in Figure 10.

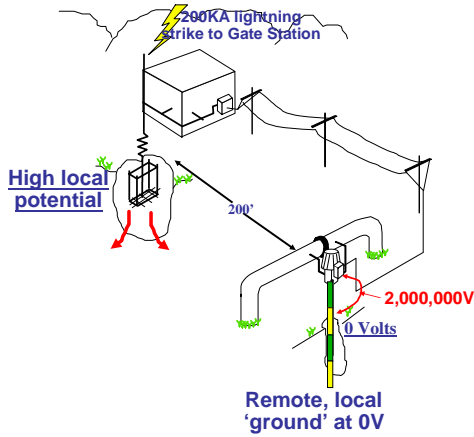

Figure 10. Lightning Strike Surge

Techniques for Floating Transmitters

Very good arguments can be made for “floating” field transmitters. Some are mechanical isolation from the piping, which can be the actual source of the surge fault currents traveling along the pipe. Others are electrical isolation and prevention of ground “loops,” the phenomena too often realized when more than one ground is referenced at different parts of the loop. Yet another sound argument is preventing the ground potential scenario presented in Figure 10.

Whatever the argument might be, if the determination is to float the field transmitter, then it becomes important to do the following. On the TSP wiring, ground the shield at the SCADA panel star point but tape back (float) the shield at the transmitter. Then, mount a hybrid surge protector such as the MTL TP48, as shown in Figure 11, in the spare conduit hole of the transmitter housing and connect the green/yellow ground wire to the transmitter ground. Complete the red/black, 4-20mA wiring connection as normal. The transmitter is now fully surge protected and floating.

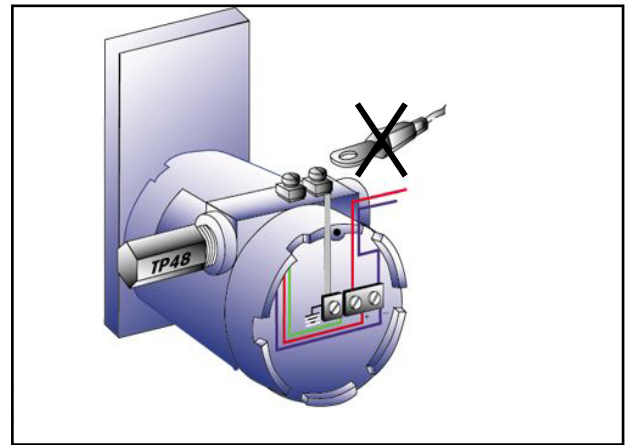

Figure 11. Transmitter Surge Protection

GROUNDING OF INTRINSICALLY SAFE SYSTEMS

The Critical 1 ohm Ground

If any plants or gate stations employ intrinsic safety zener diodes as a method of “explosion proofing”, then the ground circuits associated with that system must comply with ANSI/ISA RP12.6, 2003, and NEC504 in order to meet code.

Simply put, the ground circuit from the intrinsically safe, zener barrier to the true, power ground, shown as “X1-X” in Figure 12, must be dedicated, green or green/yellow in jacket color, 12 AWG, and measure less than one (1) ohm.

To simplify maintenance and increase reliability of the important, safety dependent, one ohm ground, a duplicate 12 AWG wire can be run alongside the first to the same points, X1-X. Then, to proof the I.S. ground at <1 ohm, an ohmmeter can be safely inserted into the circuit, even while the station is operational, and a measurement taken. As long as the reading is <2 ohms, 1 ohm down the wire to ground and 1 ohm back from the second wire, then the zener barriers will have the necessary 1 ohm ground required by code.

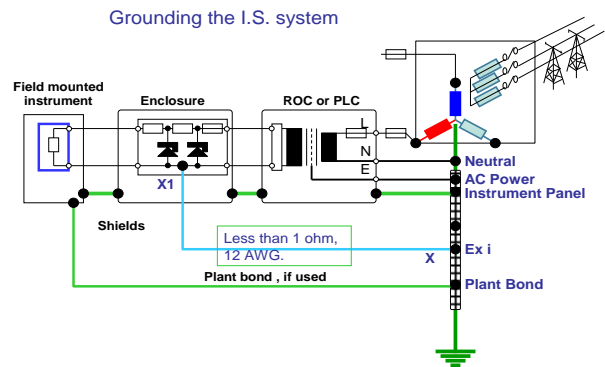

Figure 12. Intrinsically Safe Grounding Circuit

GROUNDING OF LIGHTNING AND SURGE PROTECTION

Use Dedicated Low Impedance (0.1 ohm) Connection

The bond to the station ground plane for lightning and surge protection circuits cannot be overemphasized. Ideally, the resistance to the ground plane would be less than 0.1 ohms. A recent visit to a plant experiencing severe lightning/surge problems at Cape Fear, NC, revealed a measured resistance to the ground plane at eighteen (18) ohms. A direct strike of 200,000 amperes to a lightning rod on their plant would easily produce a voltage across the entire building, by Ohm's Law: $I \times R = E$ or $200,000A \times 18R = 3,600,000V$. On recommendation, the site reduced the resistance to the ground plane to 0.1 ohms, and the same lightning surge will produce a 20,000 volt pulse. This level of surge is manageable using standard MTL hybrid MOV/Gas Discharge techniques and the facility no longer has surge related outages and damaged I/O.

GROUNDING THE CONTROL LOOP FOR SURGE PROTECTION

The plant or station instrument control loop is extremely vulnerable to the ravages of lightning and surge damage for the following reasons. First, the field instrument is usually located remotely outdoors, mounted on or adjacent to piping directly exposed to surge currents.

Second, the field transmitter is connected, usually via TSP (twisted shielded pair), in metallic conduit or wire trays over an exposed length to the station PLC/ROC I/O modules.

Third, the power supplied to the ROC is derived from an AC source, UPS, or battery back up system that is connected to the utility power and likewise susceptible to lightning/surge currents.

It is vital to the health of these loops to have hybrid surge protection located at the field transmitter, the input to the I/O module and at the AC power feed to the control system. Once this is achieved, as shown in Figure 13, then the 0.1 ohm bond described in the previous section is the final step in safeguarding the control system from lightning and surge.

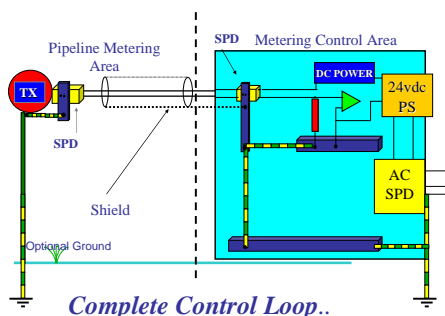

Figure 13. Complete Control Loop Diagram

SUMMARY

The topic, often heated and quite animated, of whether a plant or gate station is properly grounded will invariably arise at the same time as, or shortly after, a problem occurs. The problem may be relatively insignificant such as incorrect counts from a flow-metering loop. Or, it may be as disastrous as an explosion and resultant fire.

In any case, the fundamental rules of proper grounding must be followed. To this end, it is necessary to adopt a consistent approach throughout your systems, employing star point grounding and proper grounding bed techniques. Use as short and as heavy gauge wire to electrical ground, "mother earth" as possible. Just like a speeding tractor-trailer truck, large surge or fault currents do not take sharp bends in wires well, so provide large radius relief bends in all wiring. Install flange insulators and guards correctly. Finally, pay close attention and adhere to recommended codes of practice...they were drafted after considerable study for the safety of both you and your plant.

REFERENCES

1. Telematic Limited, A member of the MTL Instruments Group, plc., TAN (Technical Application Note) #1003/1, June, 1996, "How Lightning Interacts with Electronic Systems."
2. Measurement Technology Limited, A member of the MTL Instruments Group, plc. AN9003-7 (Application Note), November, 1999, "A User's Guide to Intrinsic Safety."
3. National Electric Code, NEC Sections 200 and 504, 2005.
4. ANSI/ISA-RP12.06.01-2003, Recommended Practice for Wiring Methods for Hazardous (Classified) Locations.