

# COMPARING PLUG & SEAT REGULATORS & CONTROL VALVES

Lamar Jones

Equipment Controls Company  
4555 South Berkeley Lake Road  
Norcross, GA 30071

## INTRODUCTION

The purpose of this paper will be to compare a plug and seat regulator to a control valve for high-pressure natural gas installations such as: power plants, city gate stations, large industrial customers, compressor stations, and storage fields. The features, benefits, capabilities, and differences of both devices will be outlined, to enable the reader to make an educated selection. In addition, acceptable design practices will be reviewed concerning sizing, gas velocities, noise levels, equipment layout, and performance. The ball valve is the most commonly used type of modulating valve for natural gas pipeline applications, for that reason, we will limit this discussion to comparison between the plug and seat regulator and versions of a 1/4 turn ball valve.

## INFORMATION REQUIRED

The basic information needed to size the device includes: inlet pressure (min/max), total load (min/max), outlet pressure (min/max), inlet and outlet pipe size, any noise level limitations, desired failure mode, and level of shut-off requirements. It is also important to know the limits of the device you are considering for the application, the manufacturer may have an optimum range of control, such as, 15 - 85% of the capacity of the device. This information may not be part of the sizing program.

## CONSIDERATIONS

In each application, the data will be evaluated and a determination made as to the type of device that will be used to accomplish the desired result. If they do not have an engineer on staff, they may elect to retain an engineering firm to design their stations, and recommend the equipment to be utilized. The concept of pressure regulation involves the movement of gas and movement creates velocity. Gas moving through a pipeline at 100 ft/sec is moving at approximately 68 mph – and at 200 ft/sec approximately 136mph. A good rule of thumb is that when inlet pressure is more than twice the outlet pressure (both absolute), critical conditions will exist and high velocity will be present. Elbows, tees, flow restricting valves, reducers, and increasers will create turbulence affecting velocity and capacity.

Another consideration is the temperature of the gas and the effect pressure reduction has on the gas. For every 15 PSI pressure drop equals 1 degree Fahrenheit temperature drop. Low temperatures can cause ice to form around the outlet piping, causing cracks in concrete pads, or

upheavals in the outlet piping. This may also create water and hydrocarbon condensate in the gas stream.

## BALL VALVE CHARACTERISTICS

In the broad meaning, a ball valve regulator is the adaptation of a shut-off valve connected in some manner to a piston. The piston is utilized to move the ball valve to some position in its normal arc of rotation, from its fully closed to its fully open position. To accomplish this, a positioner is normally utilized to divert power gas to either end of the piston while bleeding gas from the opposite end of the piston (Figure 1). The positioner is connected to some point of the connected linkage, such as the piston rod or the connecting link between the piston and valve. To direct the positioner, if it is to open or close the valve a controller is needed. The controller senses the need to increase or decrease the ball valve opening from one of many sources. For example, if the unit is on pressure control, the source is a downstream pressure point: if on flow control, the differential pressure across an orifice is the source.

A ball valve regulator could be used in almost any application where regulation is needed. It may be used as an operating or a monitor regulator, or as a relief valve. It may be installed above or below grade. The ball valve regulator is a very versatile tool; however, there are factors such as economics, noise abatement, accuracy of control, ease of maintenance and turndown that dictate if it should replace another type of regulator. A valve regulator with its piston, positioner, and controller is a costly item if a standard spring or pilot operated regulator will adequately handle the quantity of gas needed. If noise suppression is a factor, the cost of a regulator station properly designed with buried ball valve regulators could prove to be the most economical. If noise is a consideration of the proposed regulator station, a 3" ball valve regulator seems to be the minimum size practical to install below grade. The decision to use a ball valve regulator depends on many factors. The unit is not a cure-all for all regulating problems any more than any other type of regulator.

In revision work, a ball valve regulator can be used to replace other types of regulators. Flows can be increased without rebuilding the run, as increased flow capacities can be expected, providing the inlet and outlet piping are adequate. Ball valve regulators have also been used to replace the downstream shut-off valve. In this application, the ball valve regulator serves the dual purpose of shut-off valve and monitor regulator. Ball valve regulators require two different operating

**Figure 1. Typical Ball Valve Control Schematic**

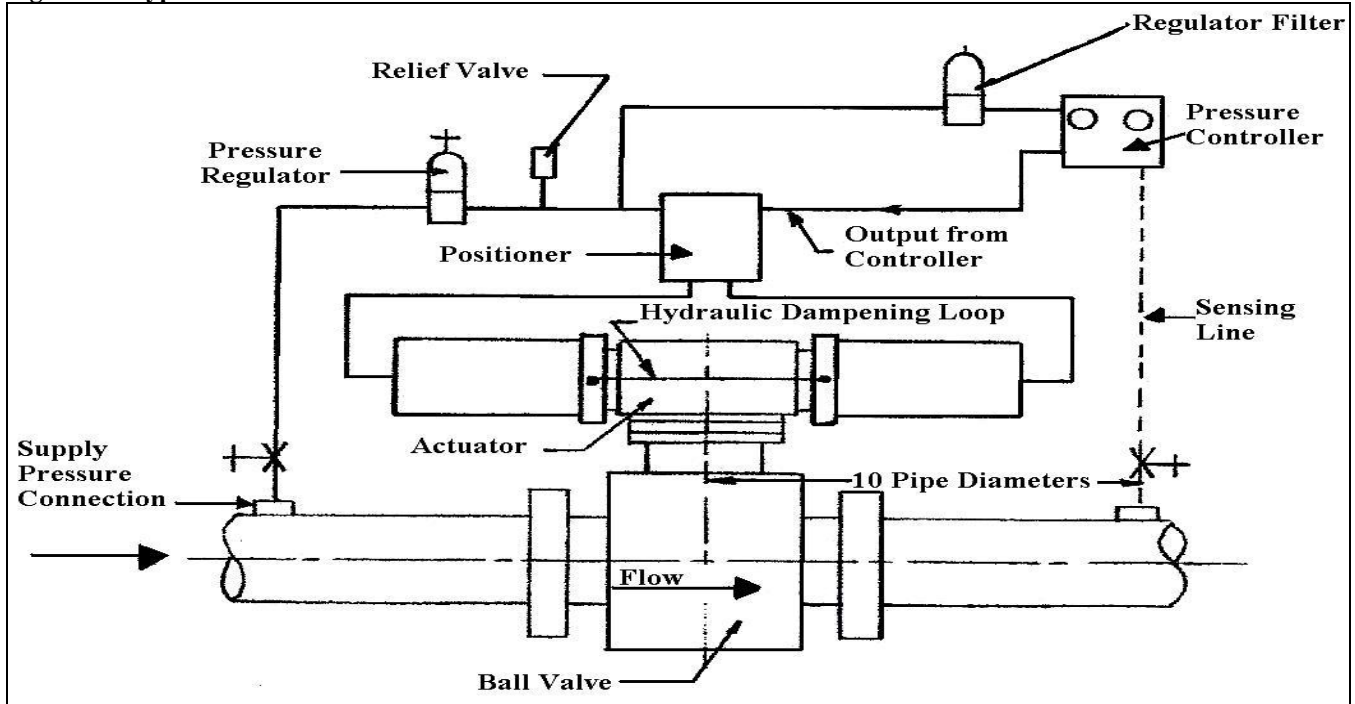

pressures—one for power gas for the piston, usually about 100 psig; the other, 20 psig for the controller. Normally, there will be one control line for the regulator and one line for the monitor regulator. Ball valves come in a range of sizes, 2" to 36" or 42" depending on the model selected.

The full ported, trunnion mounted ball valve seems to lend itself more readily to use in regulator service. The trunnion mounting allows the valve to require less turning torque. They are practically maintenance free and due to the full opening through the ball in the open position almost no pressure loss occurs. The rule of thumb concerning velocities in ball valves is to limit the gas velocity to 100 ft/sec in above grade piping and 200 ft/sec in below grade piping. Staying at or below these thresholds along with properly supporting the adjacent pipe will minimize or even eliminate any vibration that leads to mechanical wear and fatigue at the pipe joints.

**RANGEABILITY OF BALL VALVES**

In a standard, full port configuration, the ball valve possesses a 100:1 turndown ratio (See Figure 2). This classification of valve offers many derivations. With modifications made to the ball, and/or the insides of the valve enclosures, the capacity is dropped, but the turndown can be extended in excess of 250:1. The ball valve regulator, especially the modified, low-noise trim variety, offers the best rangeability (up to 300:1) (See Figure 3). The important thing to remember is that no control valve offers infinite turndown. If the application stretches the turndown limit of the control valve, consider using a higher turndown model, or installing a small pilot operated regulator in parallel to handle the lower flows. Some specialty, small port globe valves can also offer

very high turndowns (microform trim – up to 350:1). Ball valves with quiet trim must have limits to the exit velocity to prevent breaking off the trim as the slots or holes where stress risers are present. Also, keep in mind using low-noise trims can transfer the noise from the audible range to the ultrasonic range. If the station has an ultrasonic meter that noise could severely affect the operation of the meter. The ball valve is far superior to anything in its ability to tolerate and pass dirt through the wide open valve. The construction is typically a forged body (although some are cast) with either two or three piece construction. Some pipeline ball valves are of the fully welded construction, but are not serviceable.

**Figure 2.**

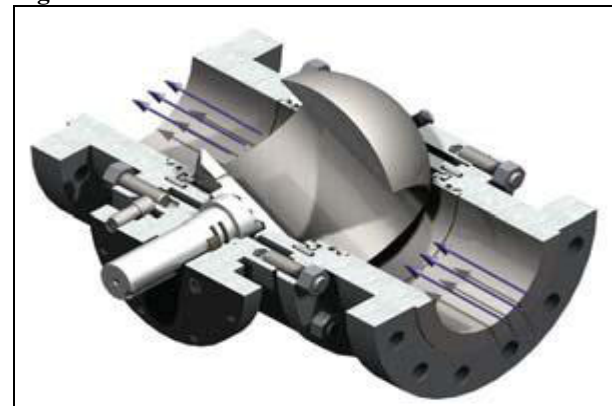

**Full Port, Trunnion Mounted Ball Control Valve**

All valves can fail. If they do, what is the failure mode? Do you want the valve to fail full open, full closed, or in last position? You may need to confirm the results you want are possible to achieve, and that you have

overpressure protection downstream if needed or required.

It is important to understand the characteristics, strengths, and weaknesses of the different types of available control valves coupled with providing accurate pressure and flow data, to arrive at an informed decision concerning the best control valve for the application.

**Figure 3.**

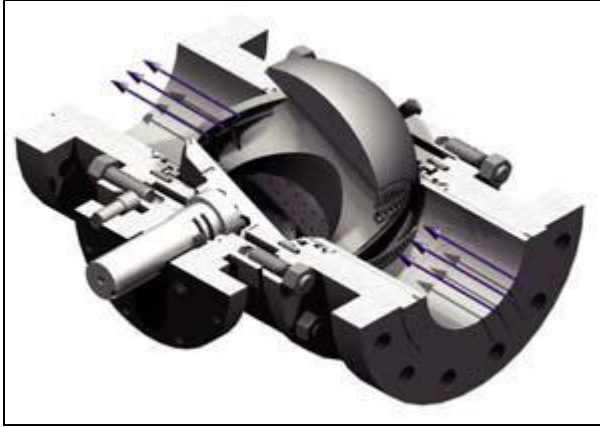

**Modified Full Port, Trunnion Mounted Ball Control Valve with Quiet Trim**

#### PLUG & SEAT REGULATORS

For the purpose of this paper, the discussion will be confined to two plug and seat style regulators; they will be designated as Regulator “A” and Regulator “B”. In most cases there will be a significant cost savings over a control valve and, there will be fewer components to deal with from a maintenance standpoint. The regulators will have a self-tuning pilot adjusting to the changing dynamics of pressure and load that occur during normal operation. The failure modes for both regulators are fail open or fail closed by design. The speed of response will be significantly faster with regulators instead of control valves. In addition, both offer optional under and over pressure protection utilizing an integral slam-shut device to completely shut-off the flow of gas in the pipeline. In-line maintenance is standard on both regulators as well as noise abatement if desired.

#### PLUG & SEAT REGULATOR “A”

This regulator has a 1500 psig inlet/outlet rating and comes in sizes 1” – 4”, and has a minimum operating differential range of 10.6 psid to 55 psid, at 90% capacity depending on type and body size. Outlet pressure range from 7.3 psig to 1160 psig depending on the pilot selected.

The pilot-operated spring to Close Version (Figure 4.) uses inlet pressure as the operating medium, which is reduced through pilot operation to load the regulator actuator diaphragm (lower chamber). Outlet or downstream pressure opposes loading pressure in the actuator and also opposes the pilot control spring. Pilot is supplied with pressure coming from pre-regulator, which reduces inlet pressure to the constant value of outlet pressure plus approximately 45 psi.

When outlet pressure drops below the setting of the pilot control spring, pilot control spring force on the pilot lower diaphragm opens the pilot valve disk, providing additional loading pressure to the lower chamber of the regulator actuator diaphragm. This diaphragm loading pressure opens the main valve disk, supplying the required flow to the downstream system. Any excess loading pressure in the lower chamber of the actuator diaphragm and on the pilot escapes downstream through a bleed restriction in the pilot.

When the gas demand in the downstream system has been satisfied, the outlet pressure increases. The increased pressure is transmitted through the downstream control line and acts under the lower spring setting and moves the pilot lower diaphragm, closing the orifice and interrupting the loading pressure supply to the lower chamber of the regulator actuator diaphragm. The excess loading pressure acting under the regulator actuator diaphragm and on the pilot lower pilot bleeds to the downstream system through a bleed restriction in the pilot.

The pilot operated spring to open version will fail in open position with a main valve diaphragm failure or lack of supply pressure to the pilot. The fail open uses the inlet pressure as the operating medium, which is reduced through pilot operation to load the regulator actuator diaphragm (lower chamber). The upper chamber of the fail open actuator and pilot are both supplied with pressure coming from pre-regulator, which reduces inlet pressure to the constant value of outlet pressure plus approximately 45 psi. This pressure on the upper chamber of the regulator actuator diaphragm opposes the main spring force that tends to open the regulator. Outlet of downstream pressure opposes the pilot control spring.

#### PLUG & SEAT REGULATOR “B”

This regulator has a design and inlet pressure rating of 1450 psig, comes in sizes 1” – 10”, with a minimum working differential of 7.25 psi. Outlet pressure range; from 5 psig to 1073 psig, depending on pilot selection. The pilot operated regulator uses inlet pressure as the operating medium, which is reduced through pilot operation to load the regulator actuator diaphragm (lower chamber). Outlet or downstream pressure opposes loading pressure in the actuator and also opposes the pilot control spring (Figure 6.). The pilot is supplied with pressure from the pre-regulator which reduces inlet pressure to a constant value of outlet pressure plus 7 – 20 psi. The pilot using a spring, diaphragm, and feedback from outlet pressure, reduces the pressure to outlet pressure plus 7 psi, and loads the lower chamber of the regulator actuator diaphragm. The unique dynamic balancing system insures an outstanding turn down ratio extremely responsive to load and downstream pressure changes. This regulator has a turndown ratio of 1000:1 and very high capacity. The seat is a vulcanized nitrile soft seat that provides repeatable bubble-tight shut-off. Inlet pressure changes do not affect the operation of this regulator, if inlet pressure is at least 7 psi more than outlet

**Figure 4. Spring to Close Regulator “A”**

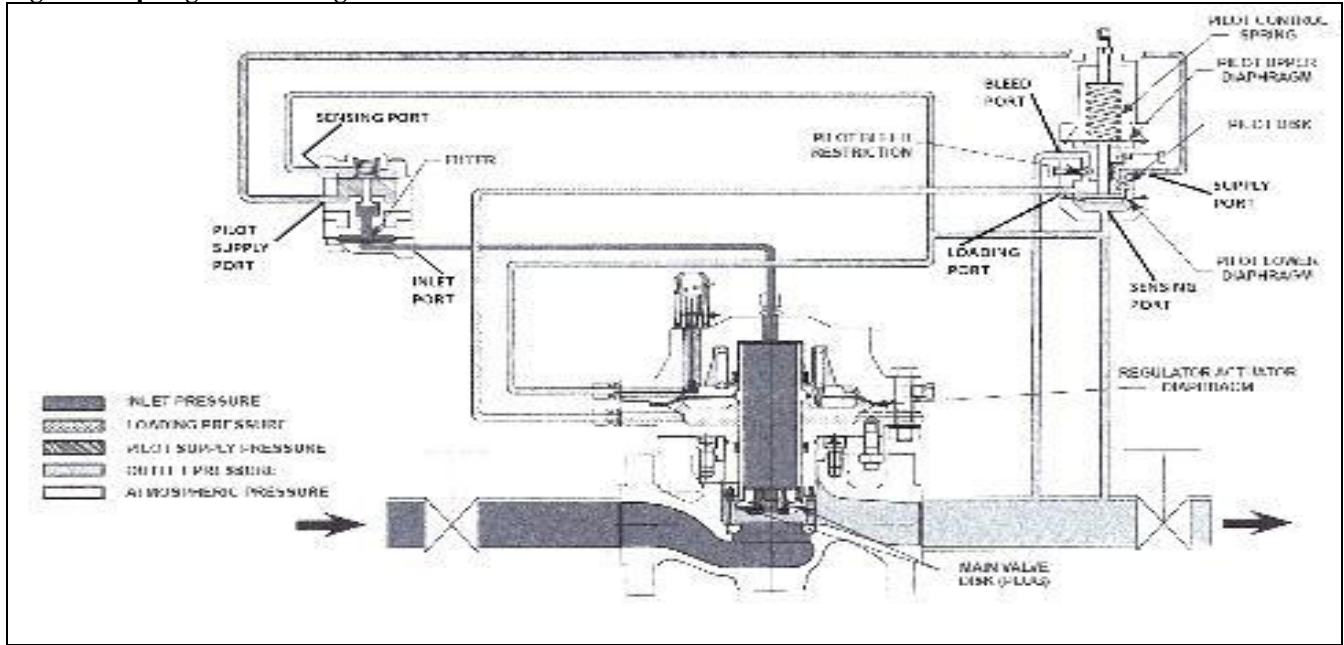

**Figure 5. Spring to Open Regulator “A”**

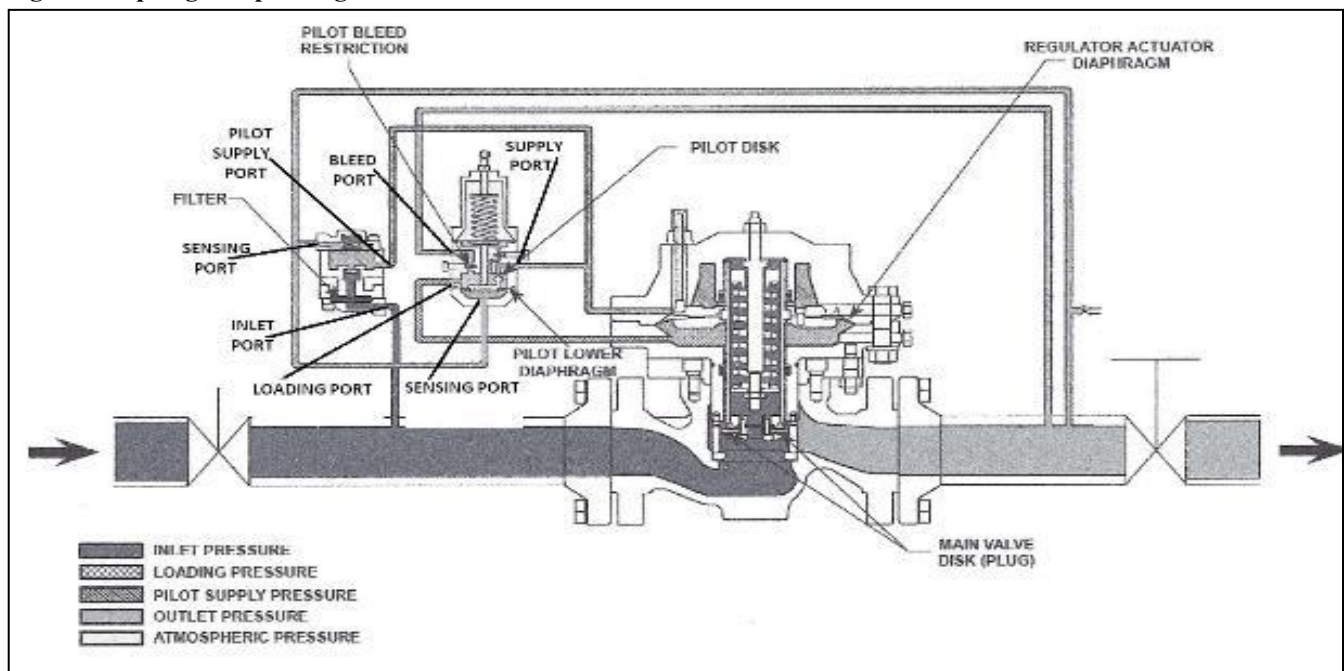

pressure, the regulator will operate and control. The regulator is very quiet under normal operating conditions, but, a silencer is available and may be retrofitted at any point in time without removing the body of the regulator from the pipeline, with no capacity loss. The regulator can be designed to fail open or closed, depending on customer preference, and is a true top-entry design. The minimum operating differential is 7 psi for the fail closed regulator and, 30 psi for the fail open regulator, the 30 psi is loaded on the underside of the controlling diaphragm and forces the plug to the open position. A travel indicator on the top of the body shows the percentage the

regulator is open. In gate station installations, a fail-open controller regulator will be installed, with the fail-closed regulator set at a higher pressure downstream as the wide open monitor. The regulator is modular in design, disconnect the tubing, remove bolts from the top of the body and all the working parts pull out in one assembly for inspection or repair.

**CONCLUSION**

It is important to understand the characteristics, weaknesses, and strengths of different types of equipment to arrive at an informed decision concerning the best

control for the application. Many factors must be considered when sizing and selecting a valve and any one of these factors could cause problems if ignored or misrepresented. Furnish your vendors with as much information as possible so they can help you make the right choice in selecting your pressure or flow control equipment. Be open minded, our industry has changed quite a bit in the last fifteen or so years, and there are better and different ways of accomplishing the tasks we are faced with today. You now have a global market to explore for solutions to your everyday needs.

**Figure 6. Spring to Close Regulator “B”**

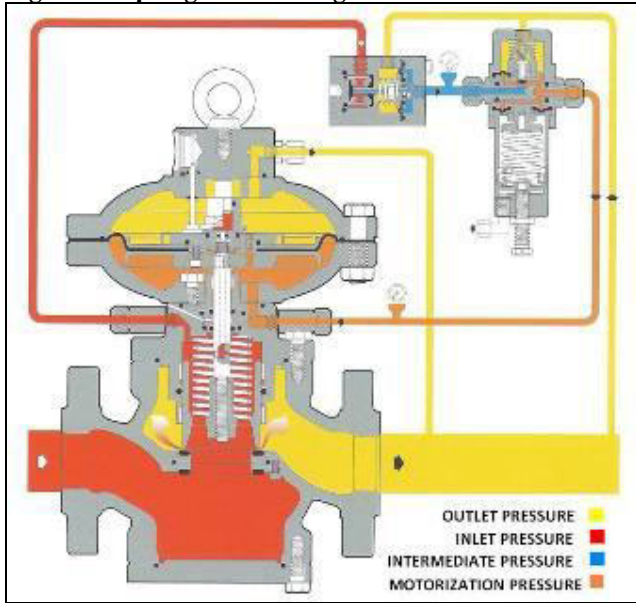

**Figure 7. Spring to Open Regulator “B”**

